

# PSD 24V Class 2 Dimming Series - Installation Instructions

Models PSD-48-24, PSD-96-24, and PSD-288-24

**Please read all instructions prior to installation and keep for future reference!**

This power supply is to be installed by a qualified electrician in accordance with the National Electrical Code (NEC) and local building codes. The power supply must be installed in a well ventilated area and free from explosive gases and vapors. Proper operation requires the free flow of air. Power supply is well suited for LED or resistive loads at or below their maximum output rating per circuit.



7777 Merrimac Ave  
Niles, IL 60714  
T 224.333.6033  
F 224.757.7557  
info@luminii.com  
www.luminii.com

PLENUM FOR SUCH USE IN ACCORDANCE WITH UL2043

REVO.1  
07012026

1 / 3

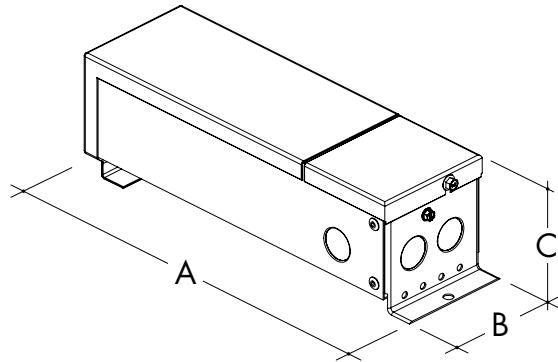

Models	PSD-48-24	PSD-96-24	PSD-288-24
A (Height)	11.39"	11.39"	13.06"
B (Width)	3.46"	3.46"	8.42"
C (Depth)	3.25"	3.25"	4.47"
Output	2.0A	4.0A	4.0A per circuit
Max Wattage	48W	96W	96W x3

\*Do not interconnect output circuits.

**1** Before installing, check the label and ensure the power supply has the proper input voltage, output voltage, and wattage for the job. Check the wire markings to ensure they match the wiring diagram below. Refer to table above for the maximum loads!

Remove the wiring compartment cover and knockouts. Wiring compartment cover held in place by hex screw.

Mount top screw first to fit in keyhole on the back of the power supply and then secure power supply on the wall with bottom screw

**2** With power off, route the input wires through knockout and connect LINE to black wire and NEUTRAL to white wire. For all wire connections use only listed wire nuts and connectors of suitable size and type.

**3** For the 48 & 96 watt version connect the positive to the red wire and negative to the black wire. For the 288 watt version (3x96W) reference diagram below. Connect the ground wire in accordance with local electrical codes.

Wiring Diagram		
+	+	+
-	+	-
+	+	+
-	+	+

Use Luminii voltage drop calculator ([LINK](#)) to calculate wire gage for low-voltage connection

# PSD 24V Class 2 Dimming Series - Installation Instructions

Models PSD-48-24, PSD-96-24, and PSD-288-24

**Please read all instructions prior to installation and keep for future reference!**

This power supply is to be installed by a qualified electrician in accordance with the National Electrical Code (NEC) and local building codes. The power supply must be installed in a well ventilated area and free from explosive gases and vapors. Proper operation requires the free flow of air. Power supply is well suited for LED or resistive loads at or below their maximum output rating per circuit.

PLENUM FOR  
SUCH USE IN  
ACCORDANCE  
WITH UL2043



REVO.1  
07012026

2 / 3



7777 Merrimac Ave  
Niles, IL 60714  
T 224.333.6033  
F 224.757.7557  
info@luminii.com  
www.luminii.com

4

## WIRING DIAGRAM

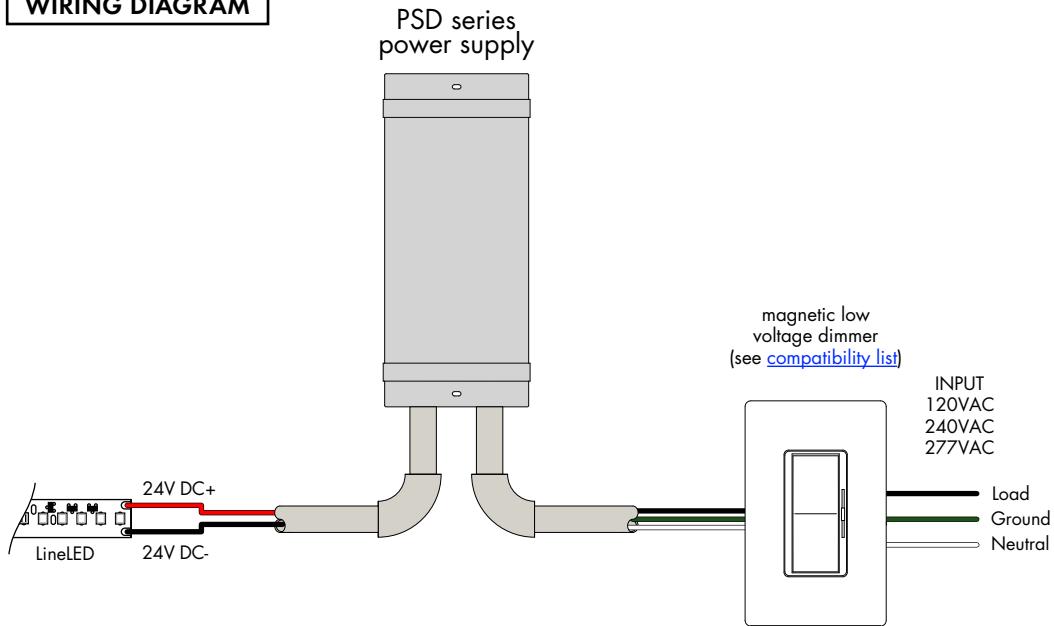

# PSD 24V Class 2 Dimming Series - Installation Instructions

Models PSD-48-24, PSD-96-24, and PSD-288-24

**Please read all instructions prior to installation and keep for future reference!**

This power supply is to be installed by a qualified electrician in accordance with the National Electrical Code (NEC) and local building codes. The power supply must be installed in a well ventilated area and free from explosive gases and vapors. Proper operation requires the free flow of air. Power supply is well suited for LED or resistive loads at or below their maximum output rating per circuit.

PLENUM FOR  
SUCH USE IN  
ACCORDANCE  
WITH UL2043



REVO.1  
07012026

3 / 3



7777 Merrimac Ave  
Niles, IL 60714  
T 224.333.6033  
F 224.757.7557  
info@luminii.com  
www.luminii.com

## CLASS 2 POWER UNIT MODELS: PSD-XX-24-XXX MOUNTING AND INSTALLATION INSTRUCTIONS

**WARNING:** The transformers and power supplies specified here must be installed by a qualified electrician in accordance with the National Electrical Code (NEC) and local building codes. Failure to do so will void the warranty and may result in serious injury and/or permanent damage to the unit.

1. This unit must be located 1 foot or greater above the deck or ground level.
2. Mount this unit on a suitable vertical surface with conduit opening down.
3. Using the ruler, measure the vertical mounting point distance for the bracket provided on the back of the enclosure.
4. Mark the mounting surface and drill a minimum of 2 holes to match the bracket holes centers. Size the drills to accommodate #10 mounting hardware.
5. If keyhole mounting brackets are provided, insert the hardware at the mounting point to allow for 3/16" spacing between the screw head and the mounting surface to accommodate the bracket thickness.
6. Refer to the product labeling for detailed line and load wiring procedure.
  - A. For connection, Use NO 12-22 AWG Cu wires insulated for a minimum of 90C, rated for 600V. Tightening torque 7 in-lbs for output terminal block.
  - B. Use wire connectors suitable for the number and size conductors being connected being connected and applied in accordance with the manufacture's instructions.
  - C. Minimum 20 amp supply side branch circuit.
  - D. A disconnect device shall be located in the field wiring.

## IMPORTANT SAFETY INSTRUCTIONS

When using electrical products, basic precautions should be practiced including the following:

1. **READ AND FOLLOW ALL SAFETY INSTRUCTIONS**
2. Read and follow all instructions that are on the product or provided with the product.
3. Reference the National code, ANSI/NFPA 70, specifically for the installation of wiring and clearances from power and lighting conductors.
4. Installation work and electrical wiring must be done by qualified person in accordance with all applicable codes and standards, including fire rated construction.
5. **WARNING:** Risk of Electrical Shock. When used outdoors, install only a circuit protected by Class A GFCI.
6. **WARNING:** Risk of fire. Installation involves special wiring methods to run through building structure. Consult a qualified electrician.
7. **WARNING:** Risk of Electrical Shock. Mount the unit at a greater height than 1 foot from the ground surface.

**SAVE THESE INSTRUCTIONS** - This insert contains important safety and operating instructions for power units.