

Features



The KRESTC-WASH Channel is a mud-in recessed wall wash fixture featuring a hyperbolic reflector for uniform lighting effect with no shadowline near the ceiling or glare. With field cuttable extrusion and pre-welded corner configurations, this flush mud-in mounted extrusion can be used in the ceiling for a wide variety of configurations. For use with 5/8" or thicker drywall.

Finish
White Powder Coat

Diffuser Lens
Polycarbonate, snap-in-place, UV resistant

Mounting
Integrated mud-in flange to be used with Number 6 size screws

Warranty
7 Years



Product Dimensions

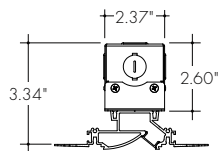
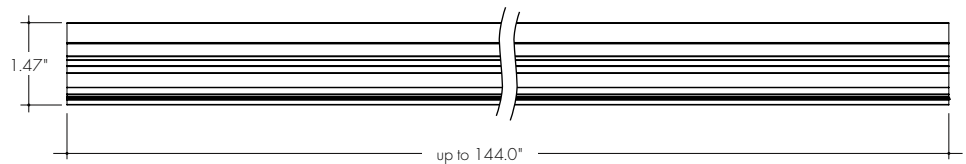
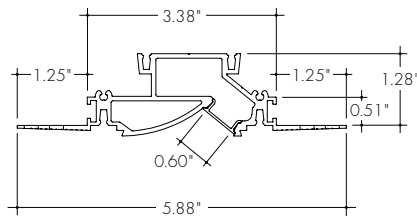

Krest Wash with Junction box attached

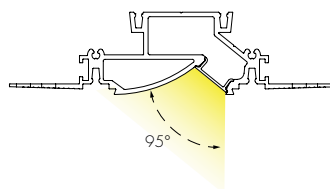

MOUNTING ACCESSORIES

EXTRUSION LENGTH	INCLUDED SCREWS
48"	6
96"	12
144"	18

TRANSMISSION PERCENTAGE
(COMPARED TO LED TAPE WITHOUT CHANNEL)

LENS	TRANSMISSION %
Frosted Lens	45%

See LED tape spec sheet for lens dotting characteristics & compatibility

Ordering Code

KREST FAMILY	MODEL	REFLECTOR	LENGTH	LENS	MOUNTING ³	FINISH
KRESTC-Krest Channel ¹	WASH-Wall Wash	H1-Hyperbolic 1" Reflector	48-48" 96-96" ² 144-144" ²	F-Frosted	GDS-Gypsum To Drywall Surface	WH-White Powder Coat

1 - Endcaps not included with Channel. Order endcaps as necessary
2 - For Channels and Lenses over 96", incremental shipping charges will apply.

3 - Mounting screws are included with channel. Refer to chart above for provided mounting screw quantities.
4 - Two front aligners are included with Channel

Krest Wash Corner Dimensions

KRESTC-WASH-H1-FIC

Inner Corner

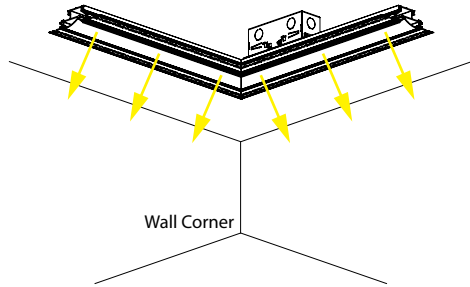

KRESTC-WASH-G1-FOC

Outside Corner

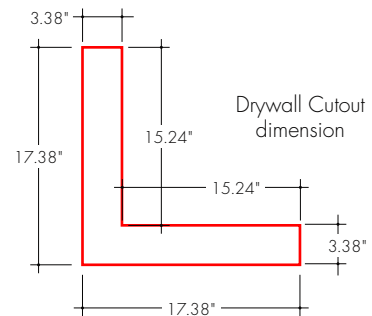
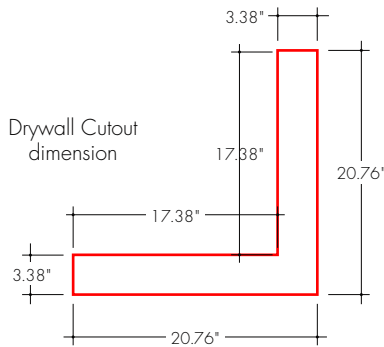
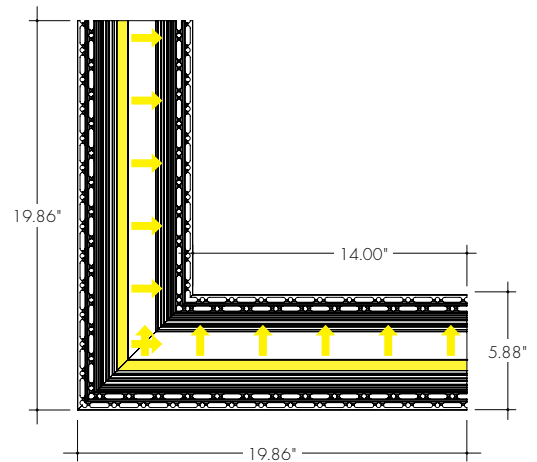
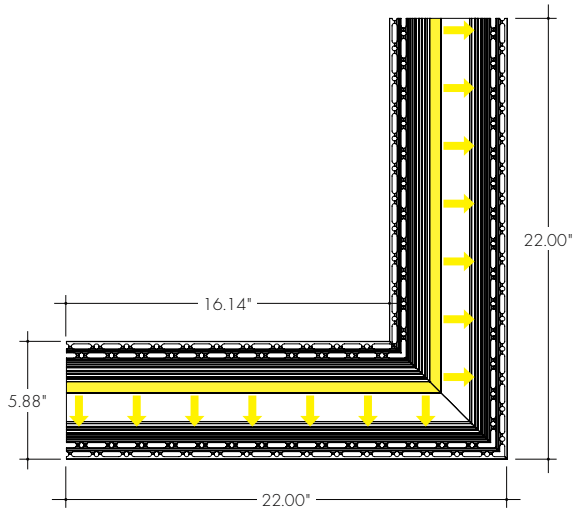
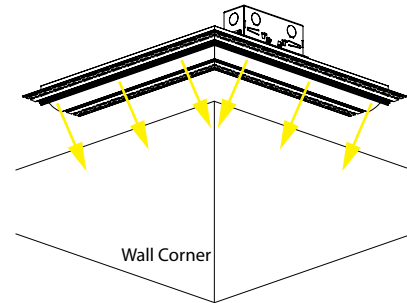

Corner Type	Actual Length	
	A	B
Flat Inside (KREST-WASH-FIC)	22.00"	22.00"
Flat Outside (KREST-WASH-FOC)	19.86"	19.86"

Ordering Code

KREST FAMILY	MODEL	REFLECTOR	CORNER TYPE	ANGLE ¹	LENS	MOUNTING	FINISH
KRESTC-Krest Channel	WASH-Wall Wash	H1-Hyperbolic 1" Reflector	FIC-Flat Inside Corner FOC-Flat Outside Corner	90-90° Corner C Custom Angle Corner ¹	F-Frosted Lens	GDS-Gypsum Drywall Surface	WH-White Powder Coat

1 - Two front aligners are included with Channel
2 - One Junction box is included with corner Channel

3 - Endcaps not included with Channel. Order endcaps as necessary.

Accessories

EC-KRESTC-WASH-H1-WH-LR

Krest endcap pair, compatible with Hyperbolic 1" Reflector Plate, White Finish

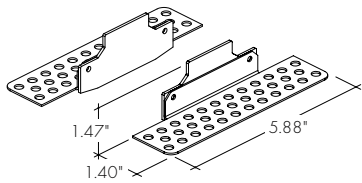

Includes both left and right endcap as well as mounting screws.

NOTE: Not included with channel - ordered separately only

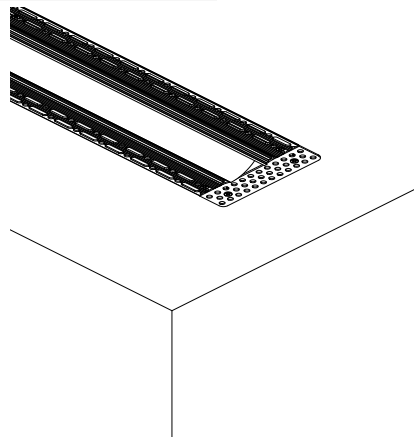

Use endcaps when ending system run in the middle of a wall.

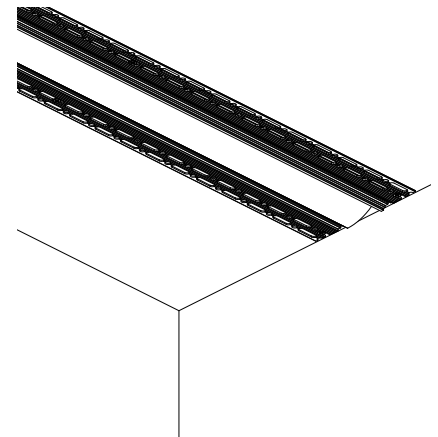

Endcaps not needed when system run ends at adjacent perpendicular wall surface

JOIN-KRESTC-WASH

Krest front aligner, two aligners included

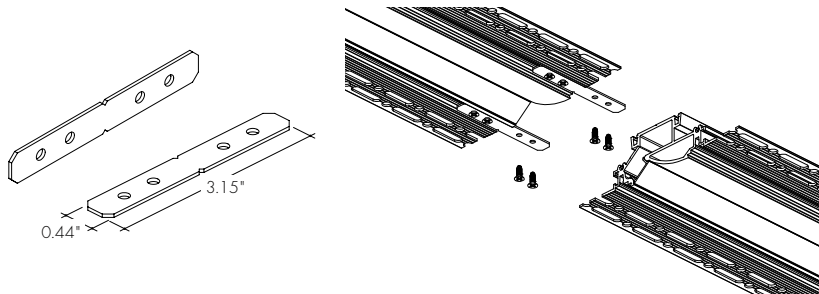

Includes necessary screws for mounting/installation. Includes two front aligners only, extrusion shown only for reference.

NOTE: Front aligners also included when ordering Krest Channel. Available to order extra as needed.

JB-KRESTC-WASH

Krest Junction Box. Attaches to Krest Wash Extrusion

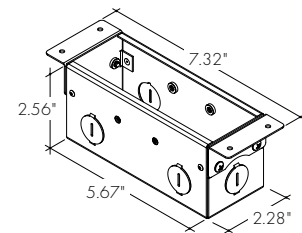

Included brackets to mechanically attach junction box to Krest Wash Extrusion. Includes mounting screws to attach to Krest Wash extrusion.

Layout Example - DIY

Corner types and straight runs are ordered individually

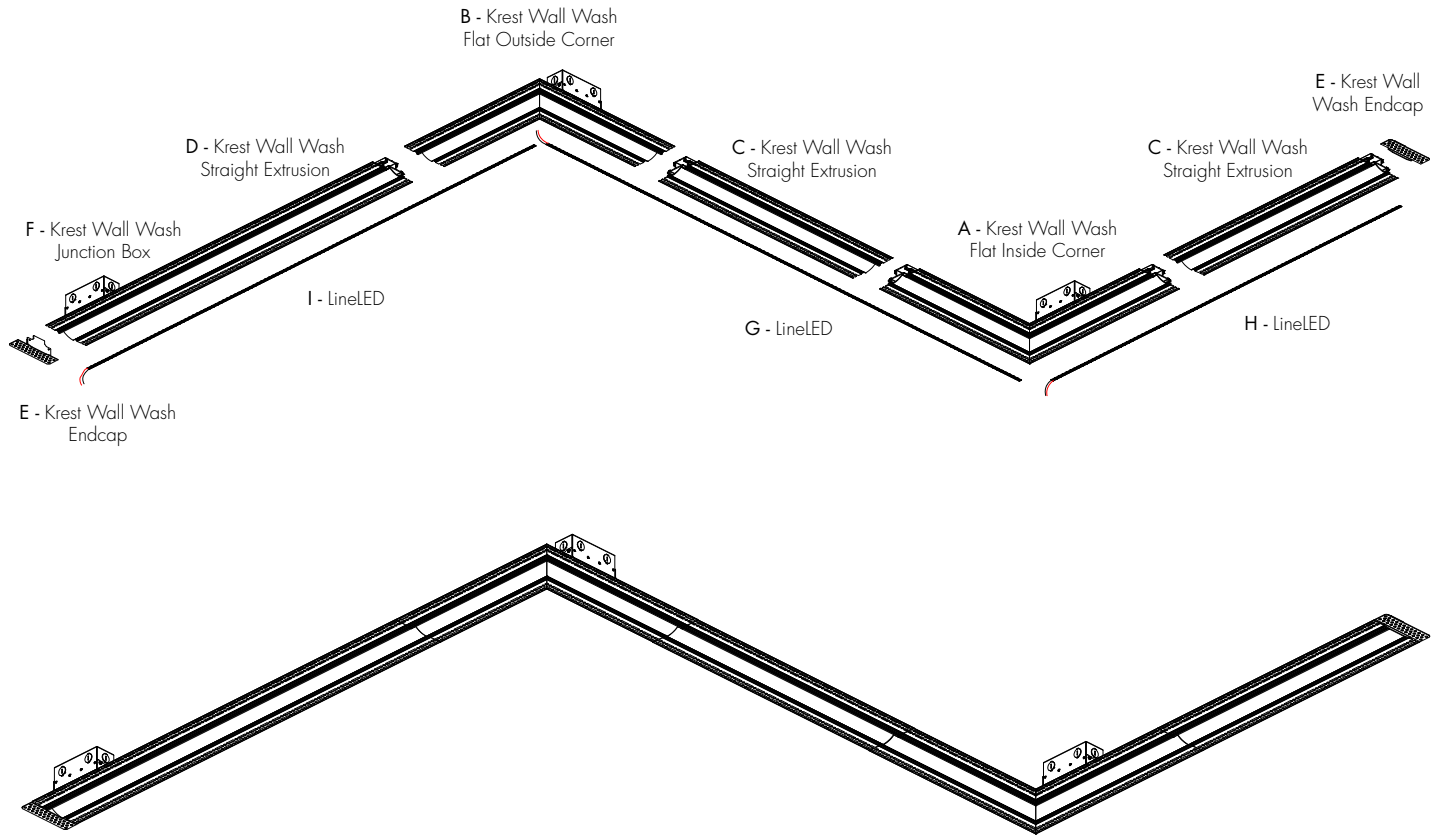

Parts and accessories required to make example layout:

ID	Part Number	Description	Quantity
A	KRESC-WASH-H1-FIC-90-F-GDS-WH	Krest Wash, Hyperbolic 1" Reflector, Flat Inside Corner, 90°, Frosted Lens, Gypsum Drywall-Surface Mounting, White Reflector	1
B	KRESC-WASH-H1-FOC-90-F-GDS-WH	Krest Wash, Hyperbolic 1" Reflector, Flat Outside Corner, 90°, Frosted Lens, Gypsum Drywall-Surface Mounting, White Reflector	1
C	KRESC-WASH-H1-48-F-GDS-WH	Krest Wash, Hyperbolic 1" Reflector, 48" Long, Frosted Lens, Gypsum Drywall-Surface Mounting, White Reflector	2
D	KRESC-WASH-H1-96-F-GDS-WH	Krest Wash, Hyperbolic 1" Reflector, 96" Long, Frosted Lens, Gypsum Drywall-Surface Mounting, White Reflector	1
E	EC-KRESC-WASH-H1-WH-LR	Krest Wash endcap pair	1
F	JB-KRESC-WASH	Junction Box (only included with corners, not straight runs)	1
Parts below are to be ordered separately			
G	LLVC72-SO-30K-SL-NC-7	LineLED, Vibrant Color, Standard Output, 3000K, Soldered lead wires (72") at one end, No connector at other end.	1
H	LLVC72-SO-30K-SL-NC-6	LineLED, Vibrant Color, Standard Output, 3000K, Soldered lead wires (72") at one end, No connector at other end.	1
I	LLVC72-SO-30K-SL-NC-10	LineLED, Vibrant Color, Standard Output, 3000K, Soldered lead wires (72") at one end, No connector at other end.	1
J	PS-UNI-60-24	Power Supply, 120-277VAC, 0-10V, Phase Dimming, 60 Watts, 24VDC	3