

Features



The KRESTC-CRNR Channel is a linear aluminum extrusion that has been designed for mud-in slot indirect lighting. With field cuttable extrusion and pre-welded corner configurations, the Krest Corner can be mounted vertically or horizontally and can span from the wall to the ceiling plane.

Finish

LED Extrusion: Silver Anodized
Reflector: White Powder Coat

Mounting

Integrated mud-in flange to be used with Number 6 size screws

Diffuser Lens

Polycarbonate, snap-in-place, UV resistant

Warranty

7 Years



Product Dimensions

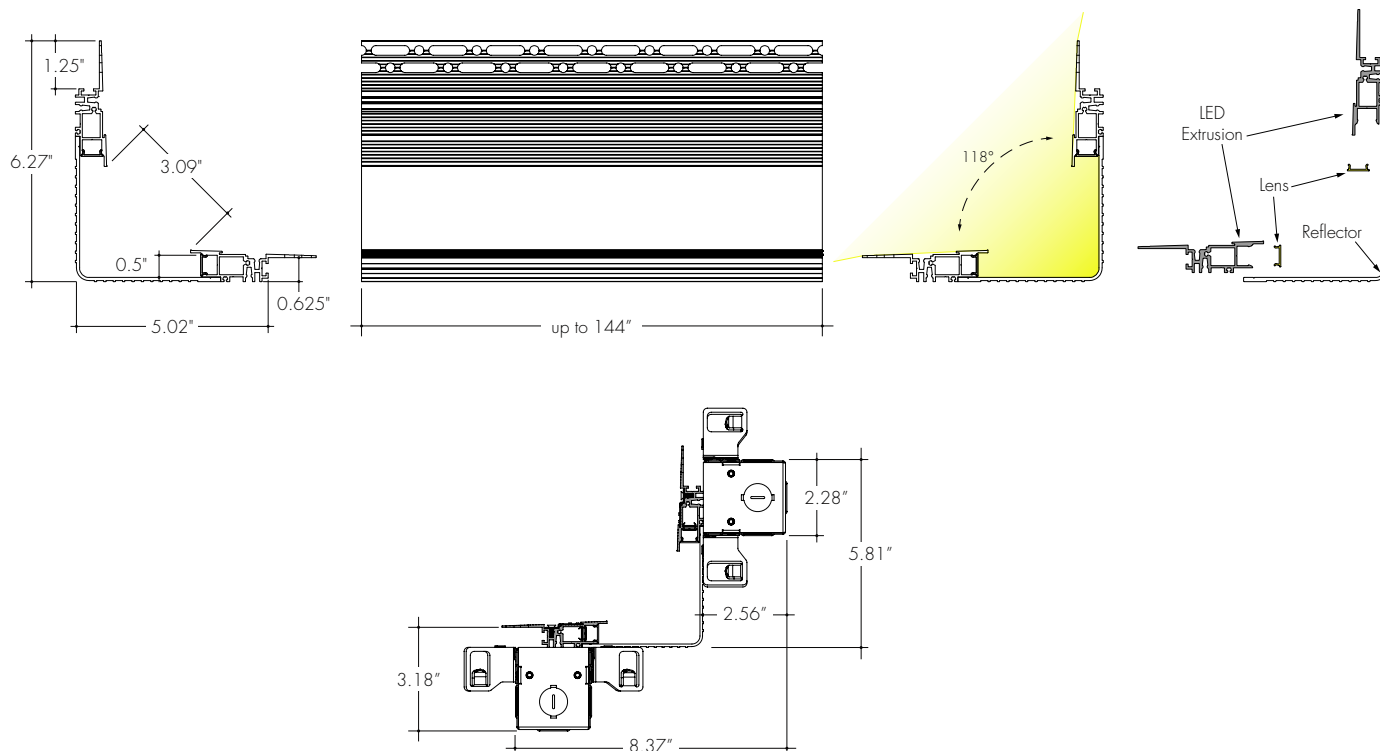

MOUNTING ACCESSORIES

EXTRUSION LENGTH	INCLUDED SCREWS
48"	6
96"	12
144"	18

Both extrusions and reflector need to be screwed into wall studs.

TRANSMISSION PERCENTAGE (COMPARED TO LED TAPE WITHOUT CHANNEL)

LENS	TRANSMISSION %
Frosted Lens	41%

See LED tape spec sheet for lens dotting characteristics & compatibility

Ordering Code

KREST FAMILY	MODEL	REFLECTOR	LENGTH	LENS	MOUNTING ²	FINISH
KRESTC-Krest Channel ¹	CRNR-Corner	Q3-Rounded Square 3" Backer Plate	48-48" 96-96" 144-144" ¹	F-Frosted	GDS-Gypsum To Drywall Surface	WH-White Powder Coat

1 - For Channels and Lenses over 96", incremental shipping charges will apply.
2 - Mounting screws are included with channel. Refer to chart above for provided mounting screw quantities.

3 - Two front aligners are included with Channel.

Krest Corner Dimensions

KRESTC-CRNR-Q3-IC

Inner Corner

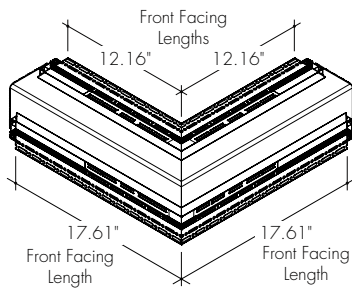

KRESTC-CRNR-Q3-OC

Outside Corner

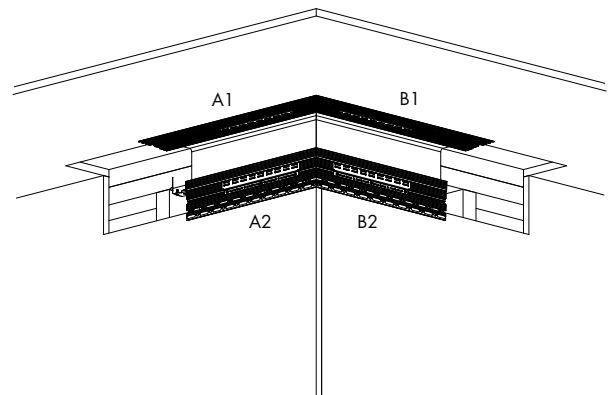
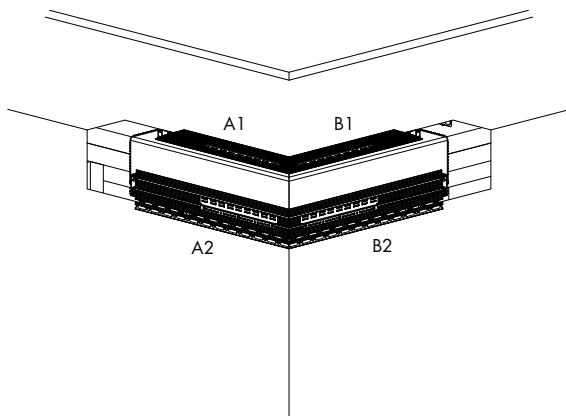
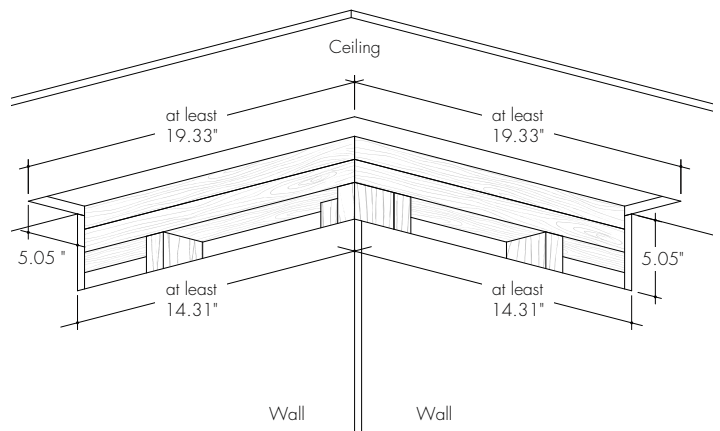
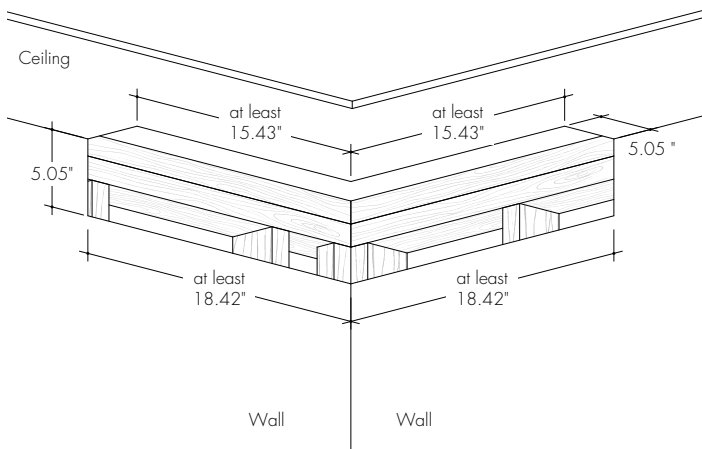
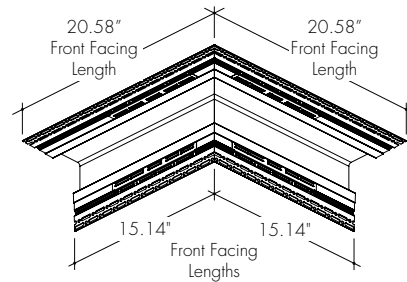

Corner Type	Actual Length			
	A1	A2	B1	B2
Inside (KRESTC-CRNR-IC)	12.16"	17.61"	12.16"	17.61"
Outside (KRESTC-CRNR-OC)	20.58"	15.14"	20.58"	15.14"

Ordering Code

KREST FAMILY	MODEL	REFLECTOR	CORNER TYPE	ANGLE ¹	LENS	MOUNTING	FINISH
KRESTC-Krest Channel	CRNR-Corner	Q3-Rounded Square 3" Backer Plate	IC-Inside Corner OC-Outside Corner	90-90° Corner C Custom Angle Corner ¹	F-Frosted Lens	GDS-Gypsum Drywall Surface	WH-White Powder Coat

1 - Two front aligners are included with Channel.
2 - Two junction boxes are included with corner Channel

Accessories

KRESTC-PF-12-SA

Krest Power Feed Extrusion, 12" long

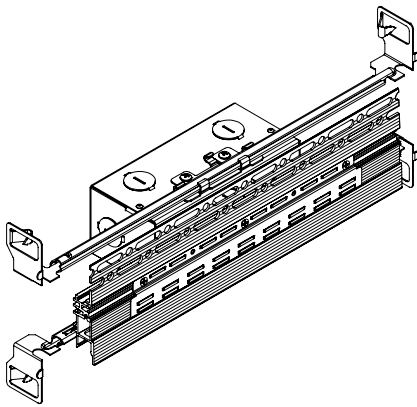

The Krest Power Feed has specially machined slots for wire management. It includes the LED extrusion, junction box, one back joiner, one front joiner, one front slot cover, and four trap door covers.

Note: Does NOT include the lens or reflector. 12" long. Two Krest Power Feeds required for Krest Corner.

JOIN-KREST-ST-KIT

Krest Joiners, front aligner (x2) and back joiner (x2)

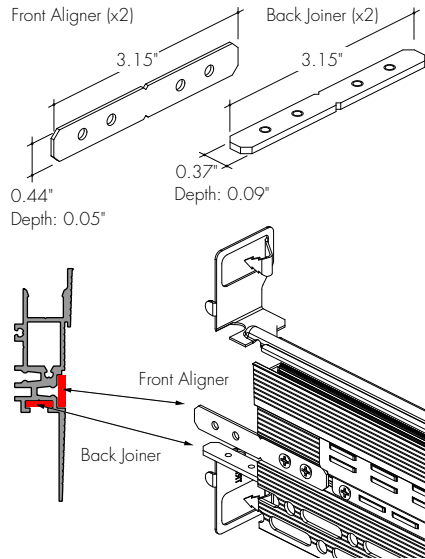

Both joiners (front aligner and back joiner) include necessary screws for mounting/installation. Includes two back joiners, two front joiners, extrusion shown for reference only.

NOTE: Two front aligners Included when ordering Krest Corner Channel. One of each joiner included when ordering Krest power feed. Available to order extra as needed.

JB-KRESTC

Krest Junction Box with Hanger Bars

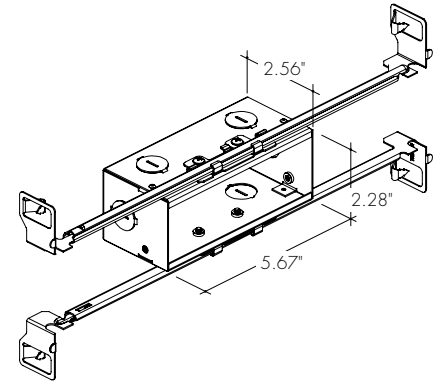

For use when wanting more than two junction boxes on the Krest Corner, Corner Channel

NOTE: Does not mechanically mate to Krest Extrusion

DUST-CVR-KRESTC

Krest Dust Cover Foam Roll

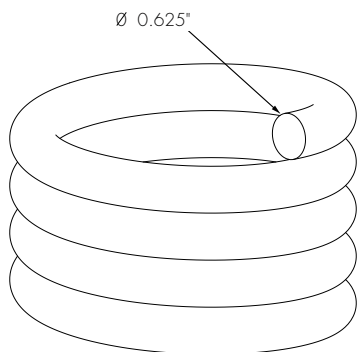

The foam dust cover is used during the installation process to protect the LED cavity during plastering.

NOTE: Sold per foot. Max continuous length is 100ft

Layout Example - DIY

Corner types and straight runs are ordered individually

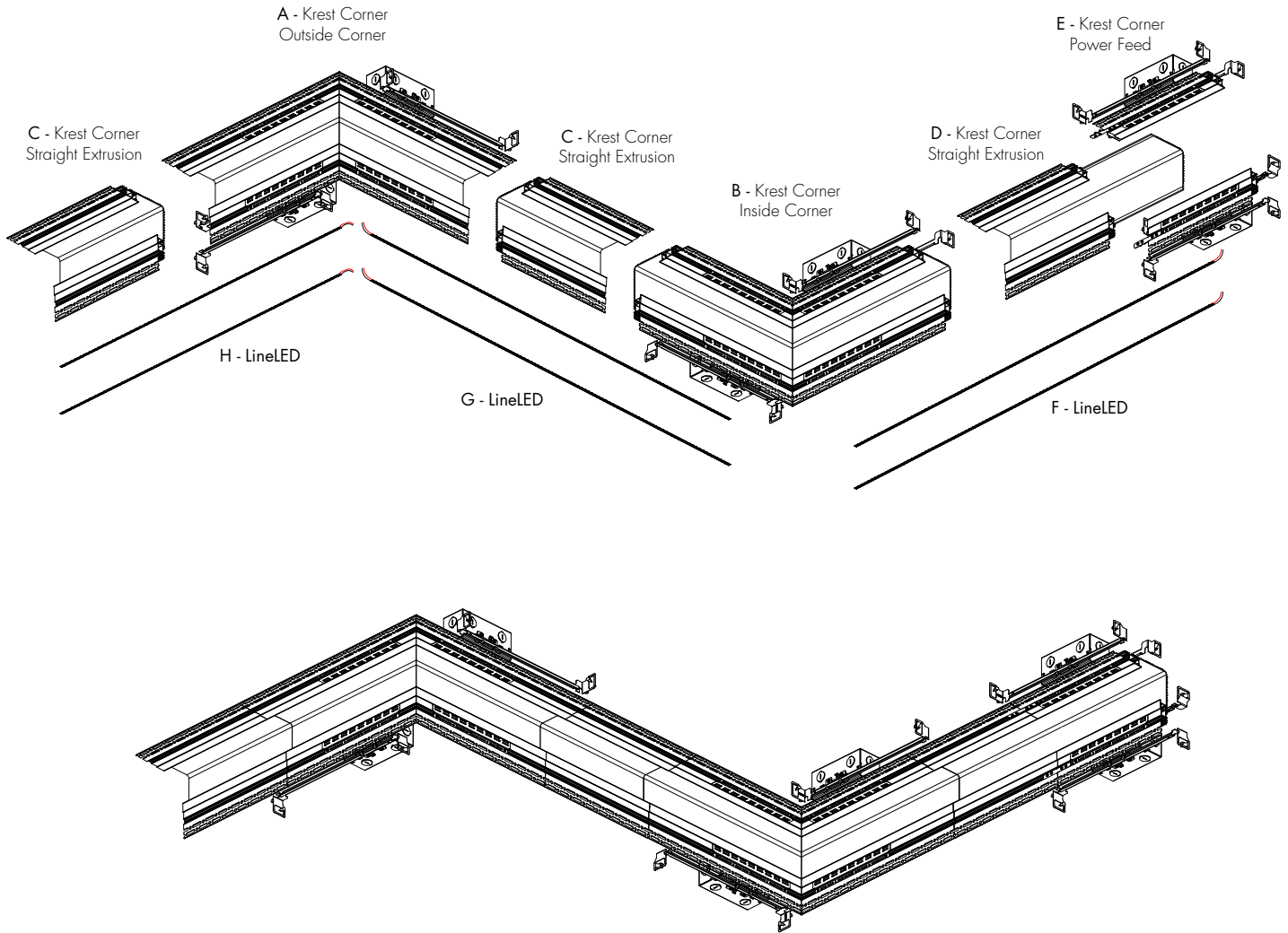

Parts and accessories required to make example layout:

ID	Part Number	Description	Quantity
A	KRESTC-CRNR-Q3-OC-90-F-GDS-WH	Krest Corner, Rounded Square 3" Reflector, Outside Corner, 90°, Frosted Lens, Gypsum Drywall-Surface Mounting, White Reflector Finish	1
B	KRESTC-CRNR-Q3-IC-90-F-GDS-WH	Krest Corner, Rounded Square 3" Reflector, Inside Corner, 90°, Frosted Lens, Gypsum Drywall-Surface Mounting, White Reflector Finish	1
C	KRESTC-CRNR-Q3-48-F-GDS-WH	Krest Corner, 3" Reflector, 48" Long, Frosted Lens, Gypsum Drywall-Surface Mounting, White Reflector Finish	2
D	KRESTC-CRNR-Q3-96-F-GDS-WH	Krest Corner, 3" Reflector, 96" Long, Frosted Lens, Gypsum Drywall-Surface Mounting, White Reflector Finish	1
E	KRESTC-PF-12-SA	Krest Power Feed Extrusion, 12" Long, Silver Anodized (doesn't include reflector or lens - meant to replace 12" of straight extrusion)	2
Parts below are to be ordered separately			
F	LLVC72-SO-30K-SL-NC-11	LineLED, Vibrant Color, Standard Output, 3000K, Soldered lead wires (72") at one end, No connector at other end.	2
G	LLVC72-SO-30K-SL-NC-7	LineLED, Vibrant Color, Standard Output, 3000K, Soldered lead wires (72") at one end, No connector at other end.	2
H	LLVC72-SO-30K-SL-NC-6	LineLED, Vibrant Color, Standard Output, 3000K, Soldered lead wires (72") at one end, No connector at other end.	2
I	PS-UNI-60-24	Power Supply, 120-277VAC, 0-10V, Phase Dimming, 60 Watts, 24VDC	3