

# EVA Standard

Fully Sealed Healthcare Grade Lamp Shade, High Performance Led Wall Sconce

alva®



Eva-12 with Island Breeze shade, ESN trim

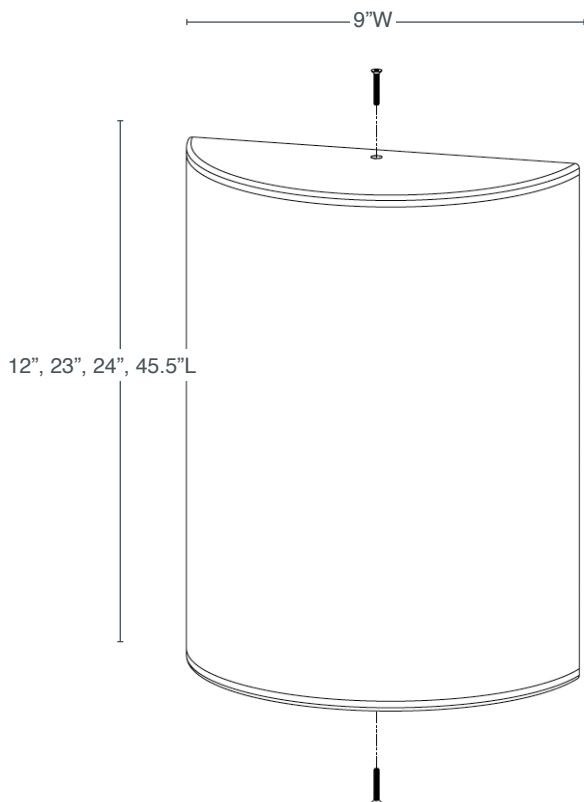

#### APPLICATIONS

- Healthcare, Senior Living, Retail, Corporate, High-Rises, Hospitality

#### MOUNTING

- Flexible mounting system allows for 1/2" incremental adjustment off of center
- Can be mounted vertically or horizontally or to ceiling

#### DIMMING

- ELV/TRIAC

#### SPECIFICATIONS

- Fully sealed lamp shade
- High Efficiency, fully integrated proprietary LED Module
- L90 - 100,000+ hours. 10 years / 24/7
- 120-277 Vac Input
- 90 CRI (minimum)

#### CERTIFICATIONS

- UL Damp Listed
- ADA Compliant
- IK10 UL Certified (protected against 20 joules of impact)
- Fully Sealed Shade
- Title 24 JA8 Certified
- BAA

#### CONSTRUCTION

- Shade: Durable ARCHITECTURAL RESIN by ALVA
- Trim: Architectural grade metal finish. Optional Antimicrobial Finish (must specify)

# EVA Standard

Fully Sealed Healthcare Grade Lamp Shade, High Performance Led Wall Sconce

alva®

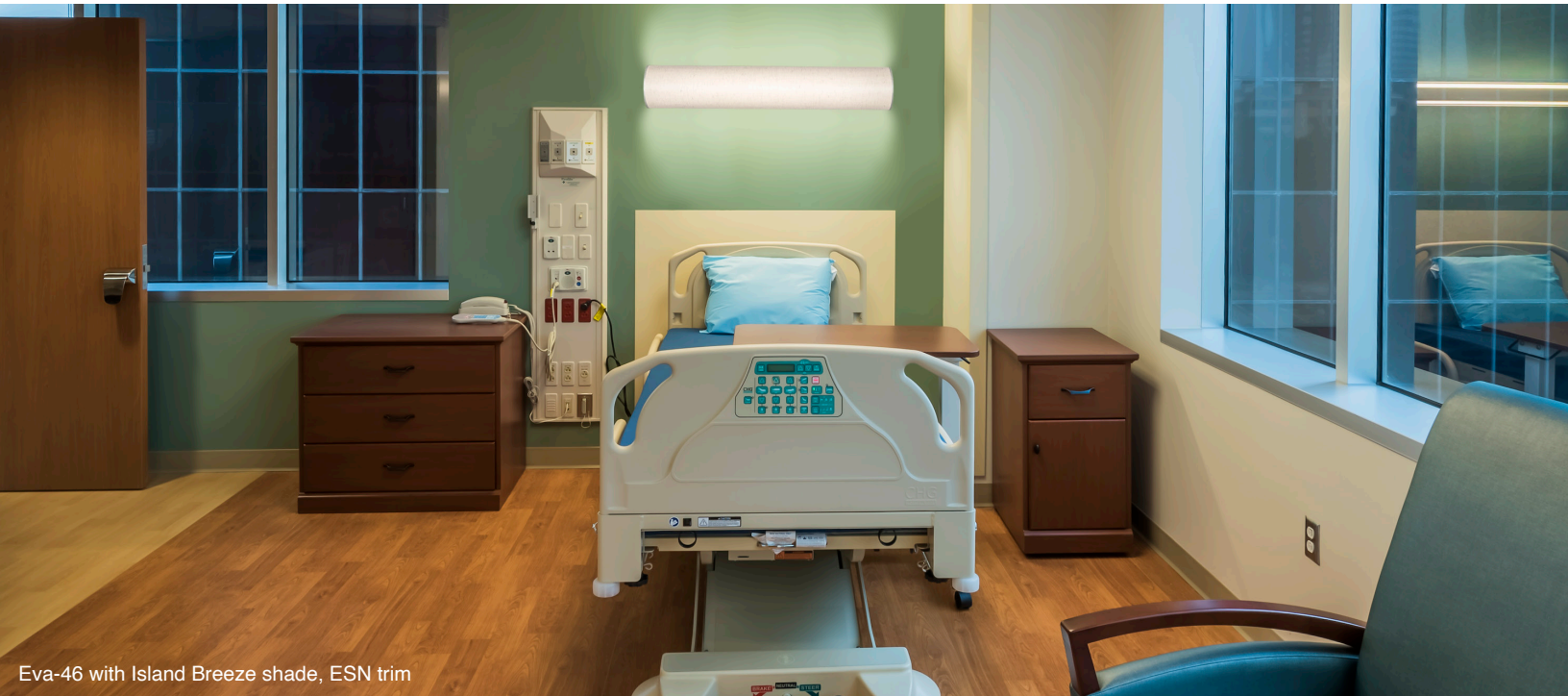

Eva-46 with Island Breeze shade, ESN trim



Eva-34 with Island Breeze shade, EOB trim

## Resin Shade Options Vandal resistant, architectural resin by ALVA®



IB - Island Breeze



GS - Gold Shimmer

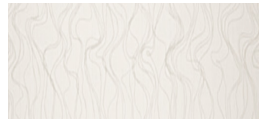

B - Burano



R - Rain



LC - Linear Cross



A - Autumn

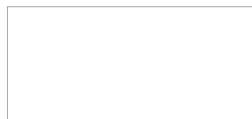

W - White Resin

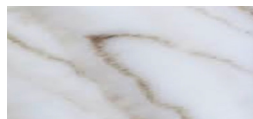

FA - Faux Alabaster

## Metal Trim Options Powder Coat Finish Options



ESN - Enviro Satin Nickel



EOB - Enviro Oil-Rubbed  
Bronze



WHT - White

# EVA Standard



Fully Sealed Healthcare Grade Lamp Shade, High Performance Led Wall Sconce

Eva is ideal for healthcare applications:

- 12”L for patient room or corridor wall sconces
- 45.5”L above patient beds



Eva-12 with Linear Cross shade  
EOB trim



Eva-46 with Island Breeze shade  
EOB trim

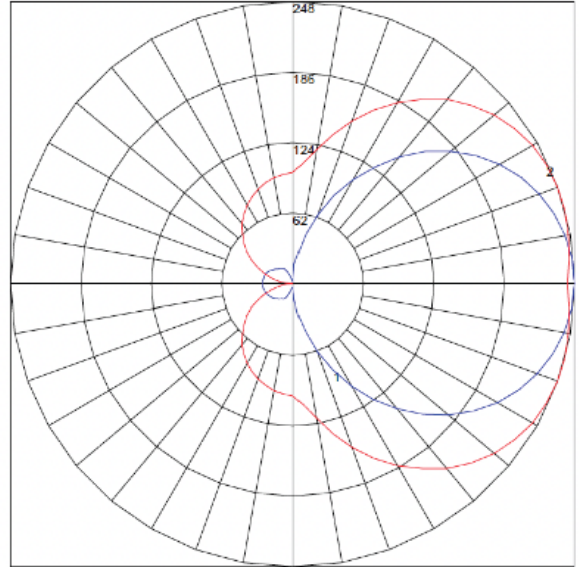

Maximum Candela – 246.08 Located At Horizontal Angle – 20, Vertical Angle = 90  
# 1 - Vertical Plane Through Horizontal Angles (20 - 200) (Through Max. Cd.)  
# 2 - Horizontal Cone Through Vertical Angle (90) (1 Through Max. Cd.)

### Photometric Report

Model	SR-23-R
CCT Tested	2700
CRI	90 min
System Wattage	30
CRI (minimum)	90
Lumens Delivered (through resin shade)	1226

MODEL	WATTS	DELIVERED LUMENS	LENGTH	WIDTH	DEPTH	WEIGHT	DIMMING	WARRANTY
Eva-12	15W	620 LM	12"	9"	3"	4 lbs	ELV/TRIAC	10 year
Eva-23	30W	1226 LM	23"	9"	3"	8 lbs	ELV/TRIAC	10 year
Eva-34	45W	1842 LM	34"	9"	3"	12 lbs	ELV/TRIAC	10 year
Eva-46	60W	2452 LM	45.5"	9"	3"	18 lbs	ELV/TRIAC	10 year

### ORDER CODE:

BRAND	LED MODULE	CCT	CRI	SHADE SHAPE	RESIN PATTERN	FINISH	ANTIMICROBIAL FINISH
<b>AU</b>							
<b>R15W</b> (SC9W12H)	<b>27</b> 2700K	<b>9</b> 90 CRI	<b>SC9W12H</b> 12"	<b>IB</b> Island Breeze	<b>ESN</b> Enviro Satin Nickel	<b>AM</b> Antimicrobial Finish	
<b>L30W</b> (SC9W23H)	<b>30</b> 3000K		<b>SC9W23H</b> 23"	<b>A</b> Autumn	<b>EOB</b> Enviro Oil-Rubbed Bronze		
<b>L45W</b> (SC9W34H)	<b>35</b> 3500K		<b>SC9W34H</b> 34"	<b>LC</b> Linear Cross	<b>WHT</b> Matte White		
<b>L60W</b> (SC9W46H)	<b>40</b> 4000K		<b>SC9W46H</b> 46"	<b>GS</b> Gold Shimmer			
				<b>B</b> Burano			
				<b>W</b> White			
				<b>FA</b> Faux Alabaster			
				<b>R</b> Rain			