

TW-DMX Controller - Installation Instructions

Models TW-DMX



7777 N. Merrimac Ave
Niles, IL 60714
T 224.333.6033
F 224.757.7557
info@luminii.com
www.luminii.com

Please read all instructions prior to installation and keep for future reference!

1. Product to be installed by a qualified electrician.
2. Prior to installation ensure power is off at fuse box to prevent electrical shock.
3. All DMX products to be installed per DMX512 Standard.

Page 1 of 3

1

120 - 240VAC wires

junction box

controller power supply

1.1 Connect the white (neutral) & black (hot) power supply wires to the white & black power wires (120 - 240VAC).

Note: All wires must be present in junction box (supplied by contractor) to connect controller properly.

2

controller face

controller housing

tab

2.1 Carefully insert a flat screw driver into the controller housing tab and slightly pull up until controller face comes off.

3

junction box

controller housing

controller screw

3.1 Loosen the screws on the back of the controller housing and make all the proper wiring and then re-tighten screws. Refer to the wiring diagram on page 2 for additional information.

terminal connection close up

+	+	+	+	+	+
DMX	DMX	DMX	DMX	DMX	DMX
+	+	+	+	+	+

4

junction box

controller housing

screw

4.1 Align the controller housing to the junction box and secure using the two screws.

5

controller housing pins

controller face

5.1 Align the back of the controller face to the controller housing pins and snap in to secure.

TW-DMX Controller - Installation Instructions

Models TW-DMX



7777 N. Merrimac Ave
Niles, IL 60714
T 224.333.6033
F 224.757.7557
info@luminii.com
www.luminii.com

Please read all instructions prior to installation and keep for future reference!

1. Product to be installed by a qualified electrician.
2. Prior to installation ensure power is off at fuse box to prevent electrical shock.
3. All DMX products to be installed per DMX512 Standard.

Wiring Diagram

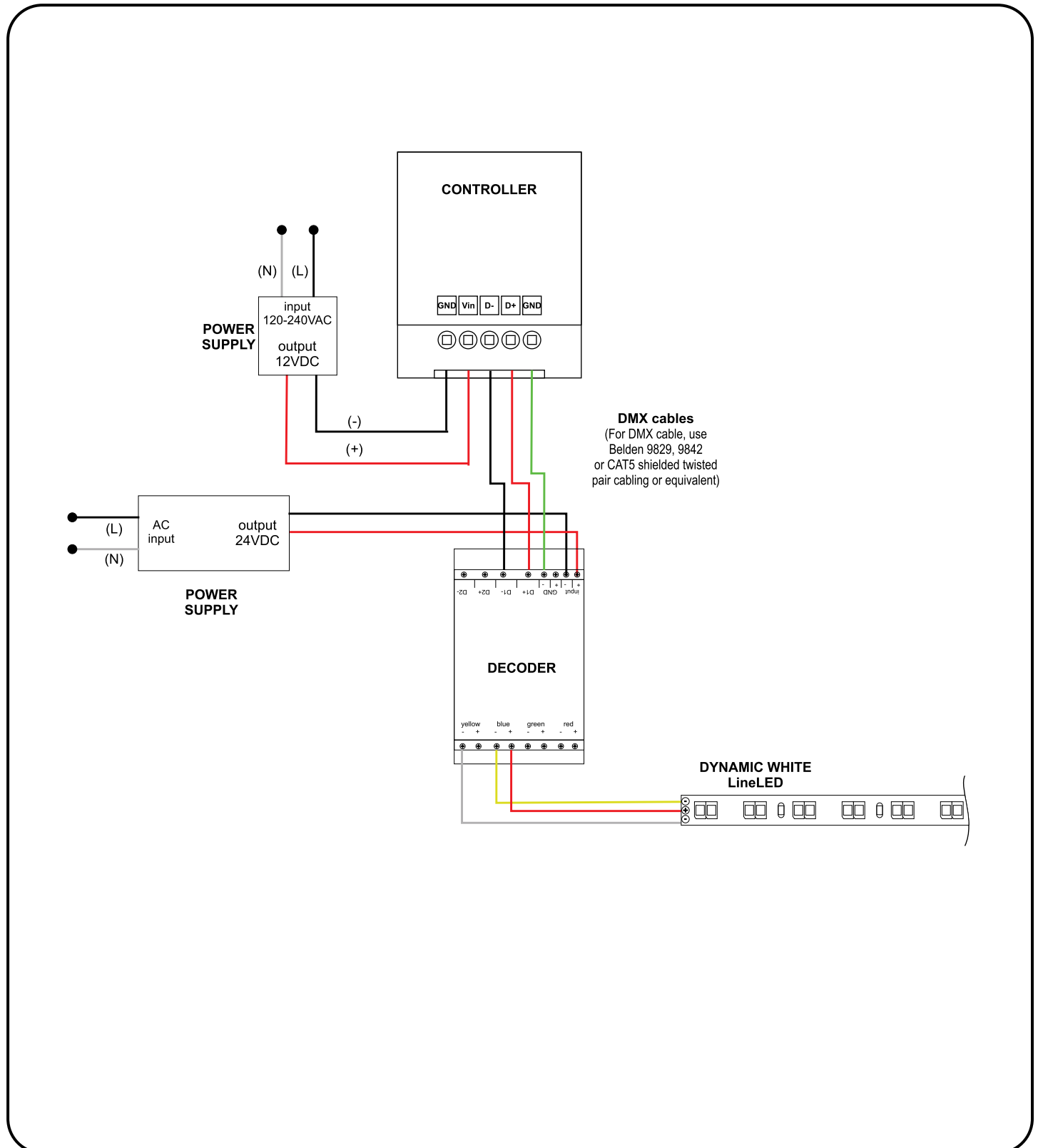

TW-DMX Controller - Installation Instructions

Models TW-DMX



7777 N. Merrimac Ave
Niles, IL 60714
T 224.333.6033
F 224.757.7557
info@luminii.com
www.luminii.com

Please read all instructions prior to installation and keep for future reference!

1. Product to be installed by a qualified electrician.
2. Prior to installation ensure power is off at fuse box to prevent electrical shock.
3. All DMX products to be installed per DMX512 Standard.

Page 3 of 3

Controller Buttons

Description of buttons

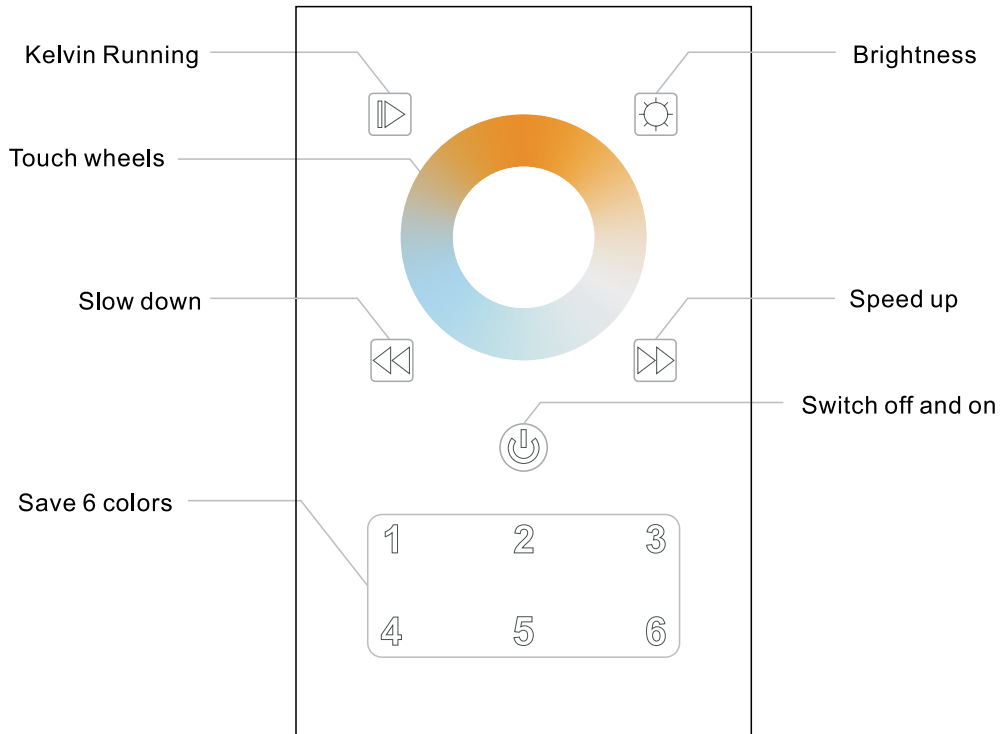

Operations

1. Set DMX Address

Set all DMX Decoder as DMX Address 001

2. Save color

1) Touch color wheel  to choose the color

2) Long press a target number over 3 seconds (light flashing means successfully saved, saving 1-6 colors will cover the original colors)

3. Default setting colors

Long press  to default settings as following colors.

- | | |
|----------------------|-------------------------------------|
| ① 100% Warm white | ② 50% warm white +50% cool white |
| ③ 100% Natural white | ④ 50% Natural white +50% cool white |
| ⑤ 100% Cool white | ⑥ 50% Cool white +50% warm white |