

Runda Closet Rod - Installation Instructions

MODEL RCR

Please read all instructions prior to installation and keep for future reference!

1. PRODUCT TO BE INSTALLED BY A QUALIFIED ELECTRICIAN.
2. MUST BE INSTALLED PER NFPA 70, ARTICLE 410.16
3. ENSURE POWER IS OFF PRIOR TO INSTALLATION TO PREVENT ELECTRICAL SHOCK
4. MORE THAN ONE PERSON IS RECOMMENDED FOR THIS INSTALLATION
5. DAMP LOCATIONS ONLY
6. USE ONLY WITH CLASS 2 POWER UNIT
7. SUITABLE FOR INSTALLATION WITHIN THE CLOSET STORAGE SPACE
8. MAX 50 POUNDS PER 1 FOOT WITH MOUNTING SUPPORTS
9. FIXTURE SHOULD BE INSTALLED BY TWO PEOPLE



REVO.7
01062025

1 / 4



7777 Merrimac Ave
Niles, IL 60714
T 224.333.6033
F 224.757.7557
info@luminii.com
www.luminii.com

Runda Closet Rod

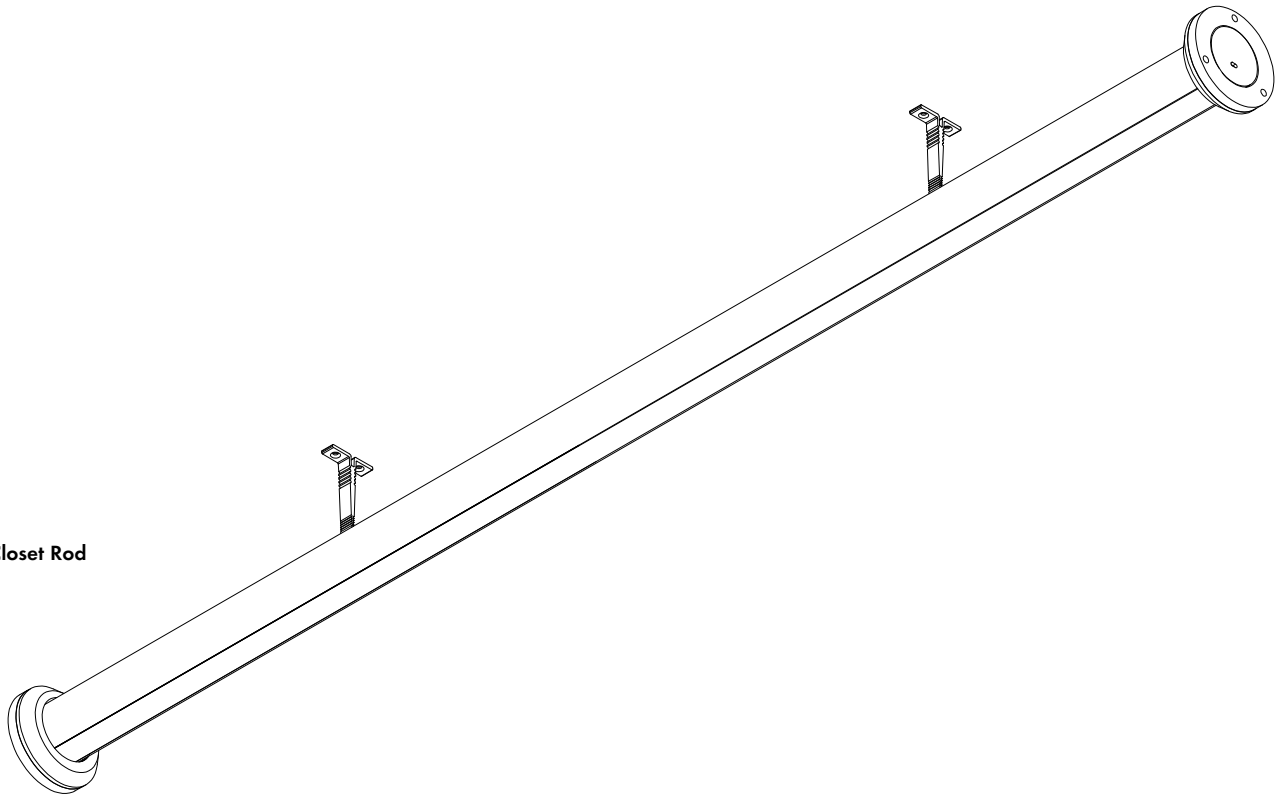

IMPORTANT SAFETY INSTRUCTIONS!

WHEN INSTALLING OR USING THIS TRACK SYSTEM, BASIC SAFETY PRECAUTIONS SHOULD ALWAYS BE FOLLOWED, INCLUDING:

- A. READ ALL INSTRUCTIONS
- B. DO NOT INSTALL ANY PART OF THE TRACK SYSTEM LESS THAN 5 FEET ABOVE THE FLOOR
- C. DO NOT INSTAL ANY LUMINAIRE ASSEMBLY CLOSER THAN 6 INCHES FROM ANY CURTAIN OR SIMILAR COMBUSTIBLE MATERIAL
- D. DISCONNECT ELECTRICAL POWER BEFORE ADDING TO OR CHANGING THE CONFIGURATION OF THE TRACK
- E. DO NOT ATTEMPT TO ENERGIZE ANYTHING OTHER THAN LIGHTING TRACK LUMINAIRES ON THE TRACK. TO REDUCE THE RISL OF FIRE AND ELECTRIC SHOCK, DO NOT ATTEMPT TO CONNECT POWER TOOLS, EXTENSION CORDS, APPLIANCE, OR THE LIKE TO THE TRACK.

Runda Closet Rod - Installation Instructions

MODEL RCR



7777 Merrimac Ave
Niles, IL 60714
T 224.333.6033
F 224.757.7557
info@luminii.com
www.luminii.com

REV.0.7
01062025

2 / 4

Please read all instructions prior to installation and keep for future reference!

1. PRODUCT TO BE INSTALLED BY A QUALIFIED ELECTRICIAN.
2. MUST BE INSTALLED PER NFPA 70, ARTICLE 410.16
3. ENSURE POWER IS OFF PRIOR TO INSTALLATION TO PREVENT ELECTRICAL SHOCK
4. MORE THAN ONE PERSON IS RECOMMENDED FOR THIS INSTALLATION
5. DAMP LOCATIONS ONLY
6. USE ONLY WITH CLASS 2 POWER UNIT
7. SUITABLE FOR INSTALLATION WITHIN THE CLOSET STORAGE SPACE
8. MAX 50 POUNDS PER 1 FOOT WITH MOUNTING SUPPORTS
9. FIXTURE SHOULD BE INSTALLED BY TWO PEOPLE

- 1.1** Measure the closet space to determine the length of the Runda closet rod you need
- 1.2** Runda Closet Rod comes with an extra 1/2" of extrusion both side of the LED that is field cuttable.
- 1.21** Make sure power to the LED is off or disconnected from the power supply.
- 1.22** Remove the inner end caps the side of the extrusion you plan to cut. Remove both if you plan to cut both sides.
- 1.23** Insert Wires into Extrusion to avoid damage during cutting.
- 1.24** Cut down the extrusion to the exact closet space you measured in step 1.1. Please be sure to NOT cut the LED.
- 1.25** Remove Wires once extrusion is cut and clean area around LED of debris.
- 1.3** Put the inner end caps back on the extrusion.

- 2.1** Slide the support brackets into the Runda Closet Rod extrusion. Support brackets must be installed every 48" for proper weight support distribution.
- 2.2** Carefully remove the protective film from the diffuser.
- 2.3** Push the mounting end cap onto each Runda Closet Rod extrusion end.

- 3.1** Run the lead wires (or DC quick connect cable) through opening in mounting surface to the remote power supply.
- 3.2** Mounting surface must be laid flat and structurally sound.
- 3.3** Remove the covers on each mounting endcap, orientate two of the three mounting holes in the up position. Then, secure each endcap into the surface using the appropriate hardware.

Runda Closet Rod - Installation Instructions

MODEL RCR



7777 Merrimac Ave
Niles, IL 60714
T 224.333.6033
F 224.757.7557
info@luminii.com
www.luminii.com

REV.0.7
01062025

3 / 4

Please read all instructions prior to installation and keep for future reference!

1. PRODUCT TO BE INSTALLED BY A QUALIFIED ELECTRICIAN.
2. MUST BE INSTALLED PER NFPA 70, ARTICLE 410.16
3. ENSURE POWER IS OFF PRIOR TO INSTALLATION TO PREVENT ELECTRICAL SHOCK
4. MORE THAN ONE PERSON IS RECOMMENDED FOR THIS INSTALLATION
5. DAMP LOCATIONS ONLY
6. USE ONLY WITH CLASS 2 POWER UNIT
7. SUITABLE FOR INSTALLATION WITHIN THE CLOSET STORAGE SPACE
8. MAX 50 POUNDS PER 1 FOOT WITH MOUNTING SUPPORTS
9. FIXTURE SHOULD BE INSTALLED BY TWO PEOPLE

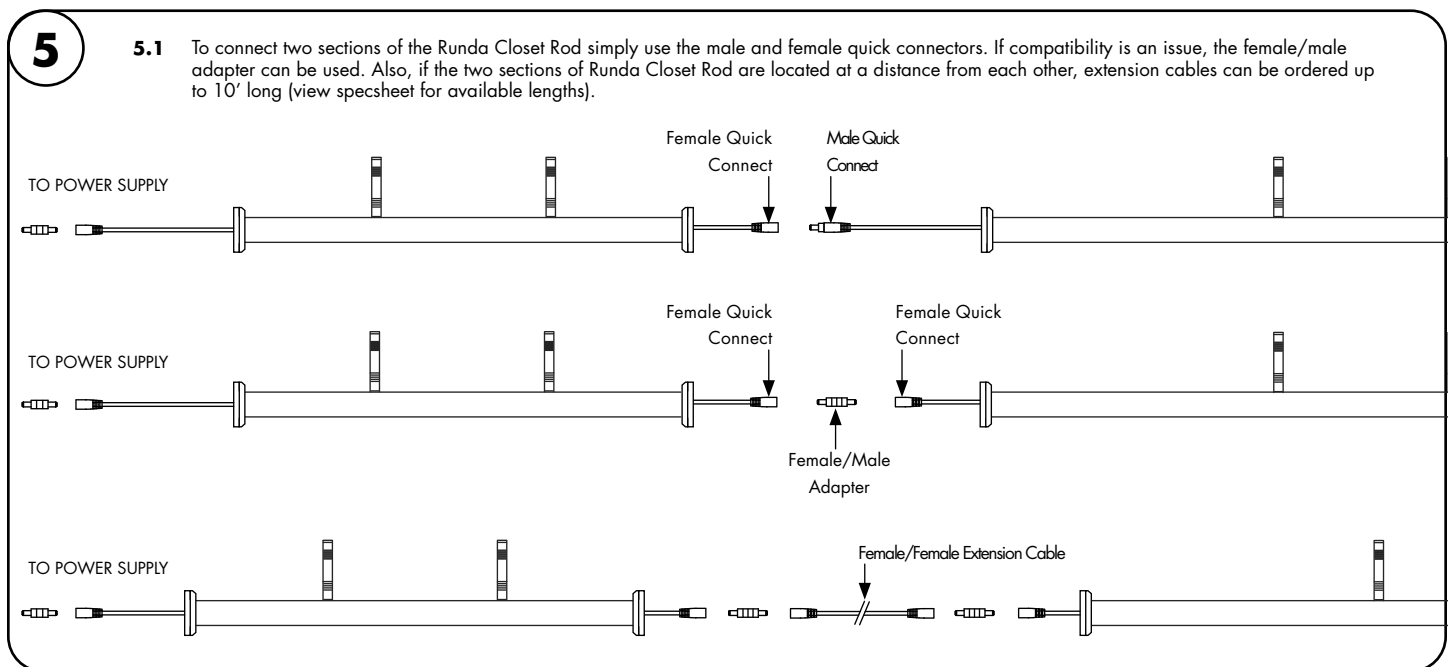
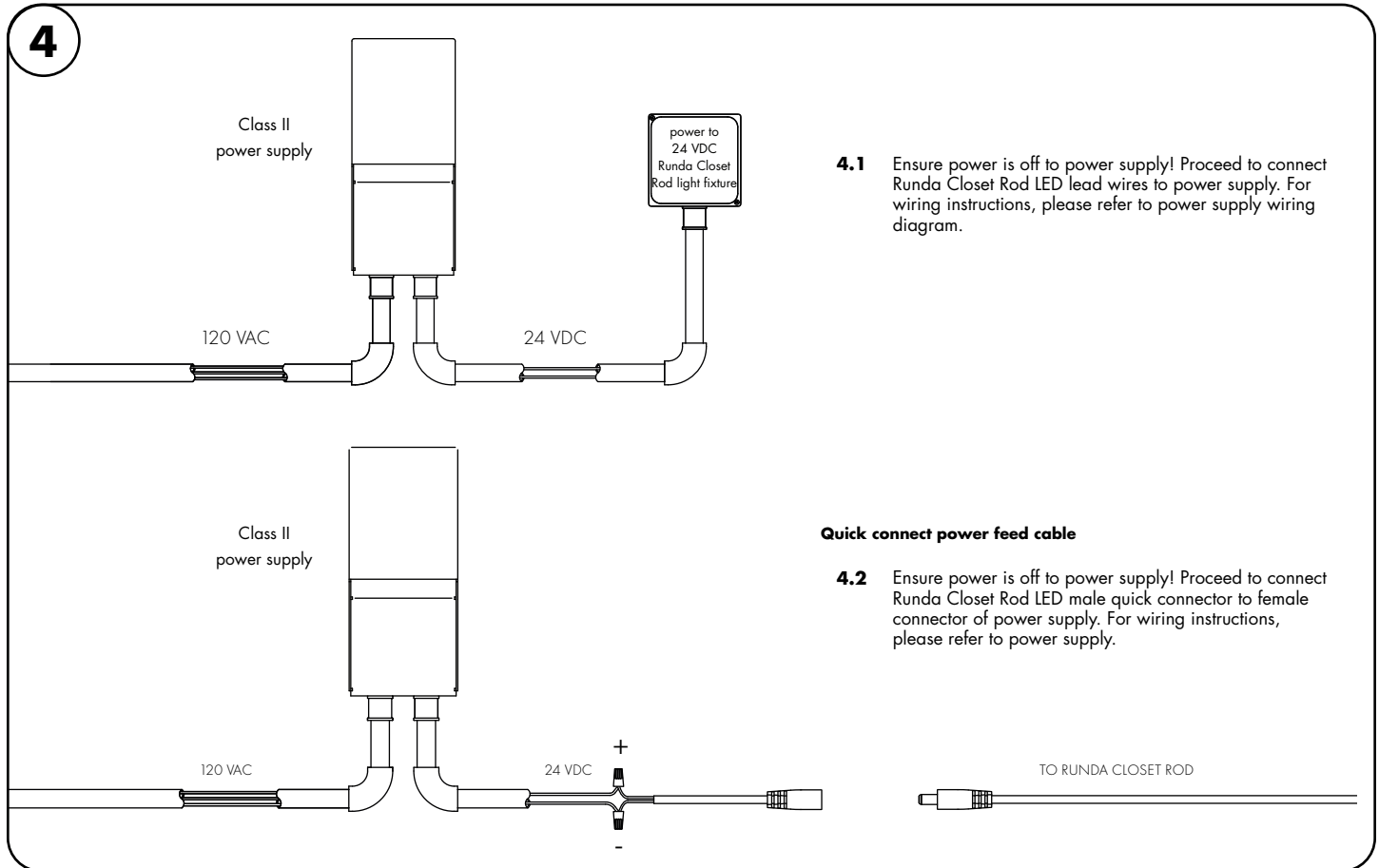

Runda Closet Rod - Installation Instructions

MODEL RCR

Please read all instructions prior to installation and keep for future reference!

1. PRODUCT TO BE INSTALLED BY A QUALIFIED ELECTRICIAN.
2. MUST BE INSTALLED PER NFPA 70, ARTICLE 410.16
3. ENSURE POWER IS OFF PRIOR TO INSTALLATION TO PREVENT ELECTRICAL SHOCK
4. MORE THAN ONE PERSON IS RECOMMENDED FOR THIS INSTALLATION
5. DAMP LOCATIONS ONLY
6. USE ONLY WITH CLASS 2 POWER UNIT
7. SUITABLE FOR INSTALLATION WITHIN THE CLOSET STORAGE SPACE
8. MAX 50 POUNDS PER 1 FOOT WITH MOUNTING SUPPORTS
9. FIXTURE SHOULD BE INSTALLED BY TWO PEOPLE



REVO.7
01062025

4 / 4



7777 Merrimac Ave
Niles, IL 60714
T 224.333.6033
F 224.757.7557
info@luminii.com
www.luminii.com

Power Supply Wiring Diagram

Note: Prior to installation all 24VDC wires must be present near fixture. Refer to the power supply installation instructions for additional information.

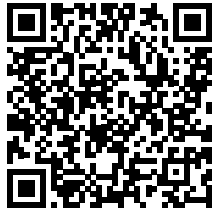

Static White
Wiring Diagram PDF