

# DALI Power Supply 3x96 Watt - Installation Instructions

## Models PS-DALI-D-3X96-24



7777 Merrimac Ave  
Niles, IL 60714  
T 224.333.6033  
F 224.757.7557  
info@luminii.com  
www.luminii.com

Please read all instructions prior to installation and keep for future reference!

This class 2 power supply is to be installed by a qualified electrician in accordance with the National Electrical Code (NEC) and local building codes. The power supply must be installed in a well ventilated area and free from explosive gases and vapors. Proper operation requires the free flow of air. Power supply is well suited for LED or resistive loads at or below their maximum output rating per circuit. Suitable For Damp Location.

PLENUM FOR SUCH USE IN ACCORDANCE WITH UL2043

REVO.2  
09192024

1 / 2

**WARNING! Risk of Fire or Electric Shock, Do Not Interconnect Output Terminal.**

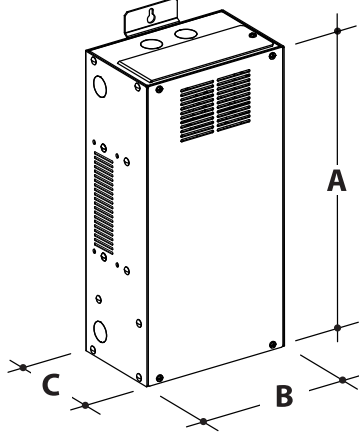

Models	PS-DALI-D-3X96-24
A. Height	13.00"
B. Width	6.60"
C. Depth	4.20"
MAX Load	3 x 96 Watts

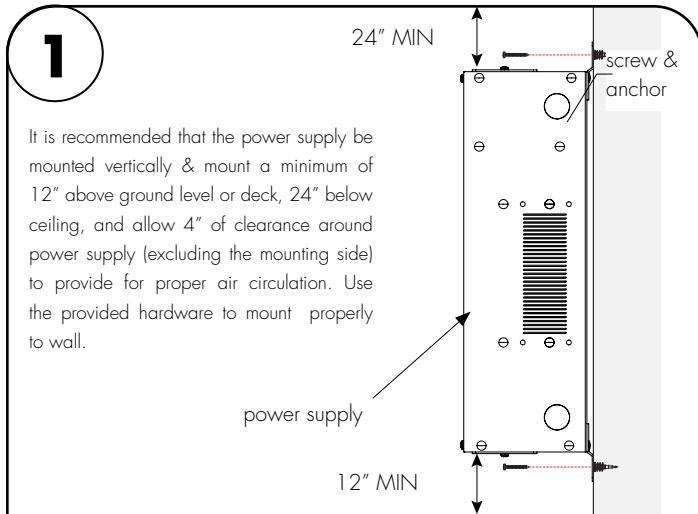

**1**

It is recommended that the power supply be mounted vertically & mount a minimum of 12" above ground level or deck, 24" below ceiling, and allow 4" of clearance around power supply (excluding the mounting side) to provide for proper air circulation. Use the provided hardware to mount properly to wall.

**1.1** Before installing, check the label and ensure the power supply has the proper input voltage, output voltage, and wattage for the job. Check the wire markings to ensure they match the wiring diagram below. Refer to table above for the maximum loads supported by each power supply.

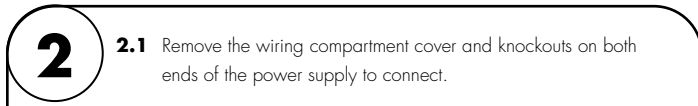

**2**

**2.1** Remove the wiring compartment cover and knockouts on both ends of the power supply to connect.

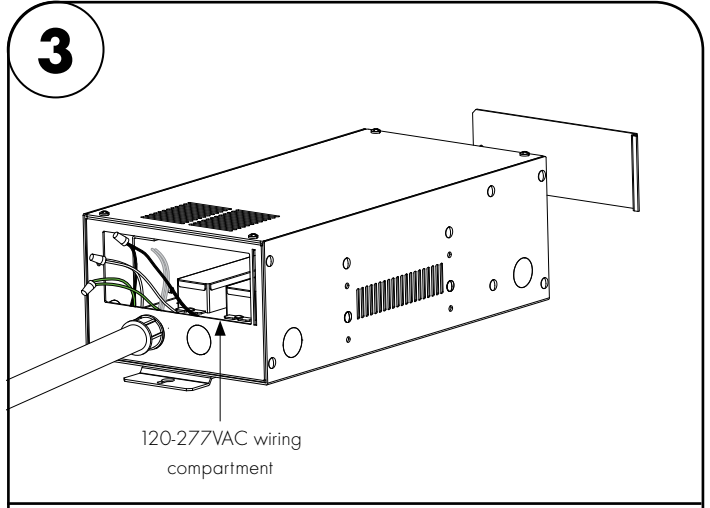
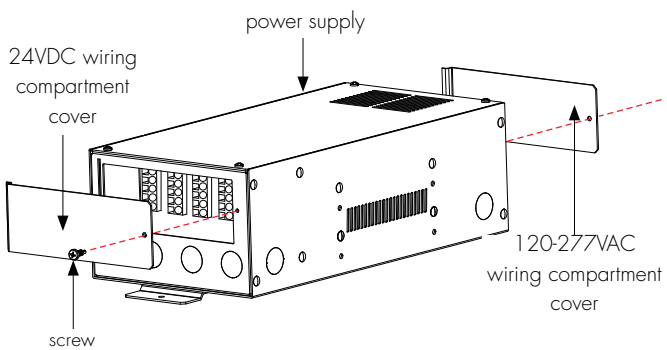

**3**

**3.1** Connect the white (neutral) and black (hot) power supply wires to the white and black power wires ( 120 - 277 VAC ). Followed by connecting the ground wires in accordance with local electrical codes.

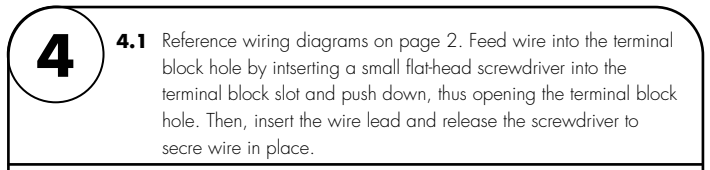

**4**

**4.1** Reference wiring diagrams on page 2. Feed wire into the terminal block hole by inserting a small flat-head screwdriver into the terminal block slot and push down, thus opening the terminal block hole. Then, insert the wire lead and release the screwdriver to secure wire in place.

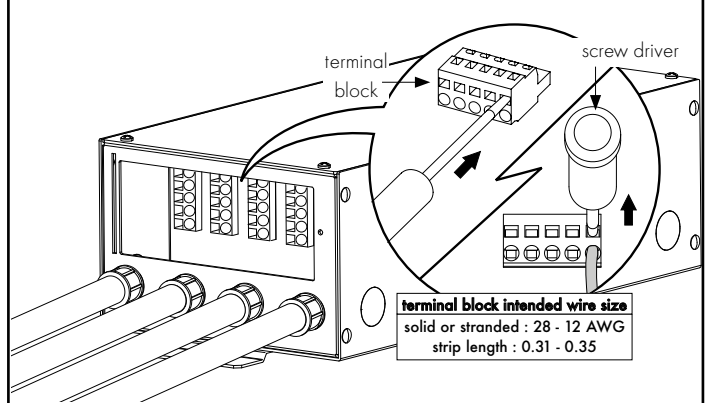

use Luminii voltage drop calculator (<http://www.luminii.com/voltage-drop-calculator>) to calculate wire gage for low-voltage connection

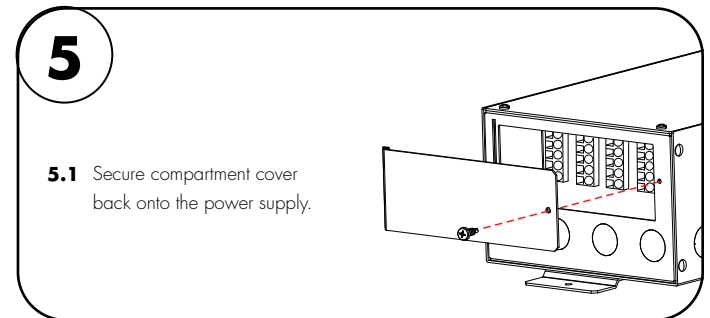

**5**

**5.1** Secure compartment cover back onto the power supply.

# DALI Power Supply 3x96 Watt - Installation Instructions

## Models PS-DALI-D-3X96-24



7777 Merrimac Ave  
 Niles, IL 60714  
 T 224.333.6033  
 F 224.757.7557  
 info@luminii.com  
 www.luminii.com

Please read all instructions prior to installation and keep for future reference!

This class 2 power supply is to be installed by a qualified electrician in accordance with the National Electrical Code (NEC) and local building codes. The power supply must be installed in a well ventilated area and free from explosive gases and vapors. Proper operation requires the free flow of air. Power supply is well suited for LED or resistive loads at or below their maximum output rating per circuit. Suitable For Damp Location.

PLENUM FOR SUCH USE IN ACCORDANCE WITH UL2043

REVO.2  
 09192024

2 / 2

**WARNING! Risk of Fire or Electric Shock, Do Not Interconnect Output Terminal.**

