

# PLA Channel - Installation Instructions

**Please read all instructions prior to installation and keep for future reference!**

1. Product should be installed by a qualified electrician.
2. Prior to installation ensure power is off at fuse box to prevent electrical shock.
3. If extrusion is installed facing up and in a wet location, ensure proper drainage and silicone endcaps and diffuser lens.

Page 1 of 2

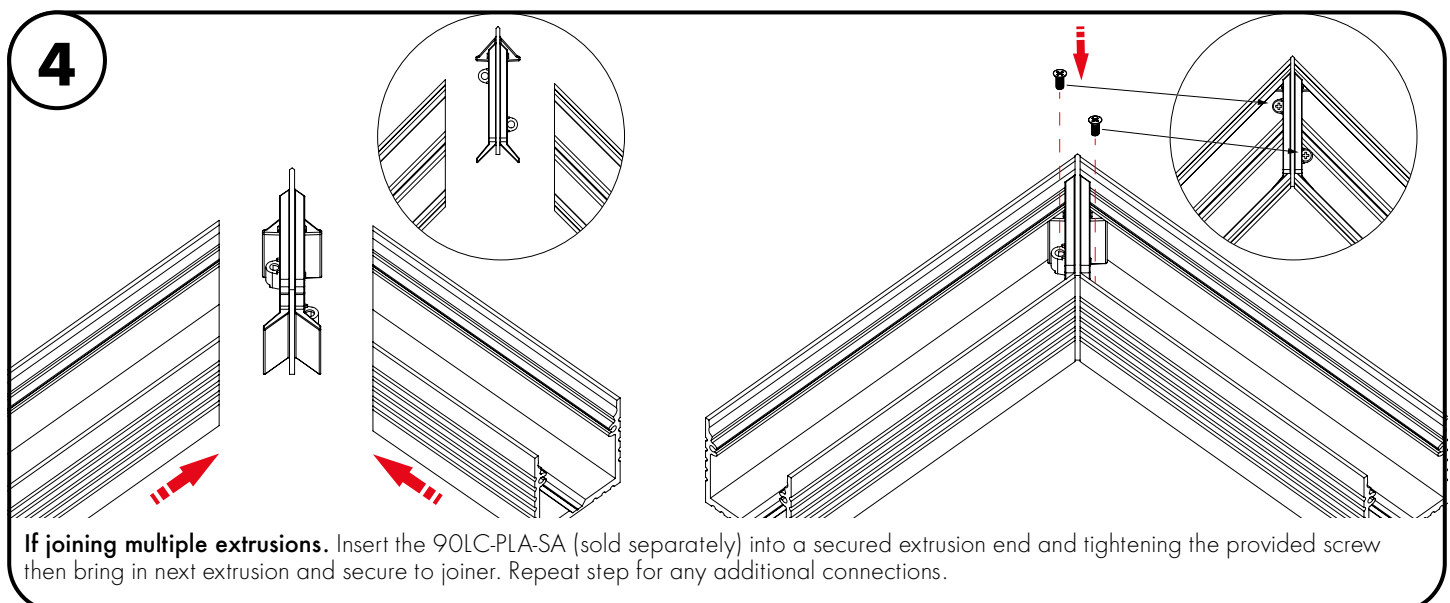
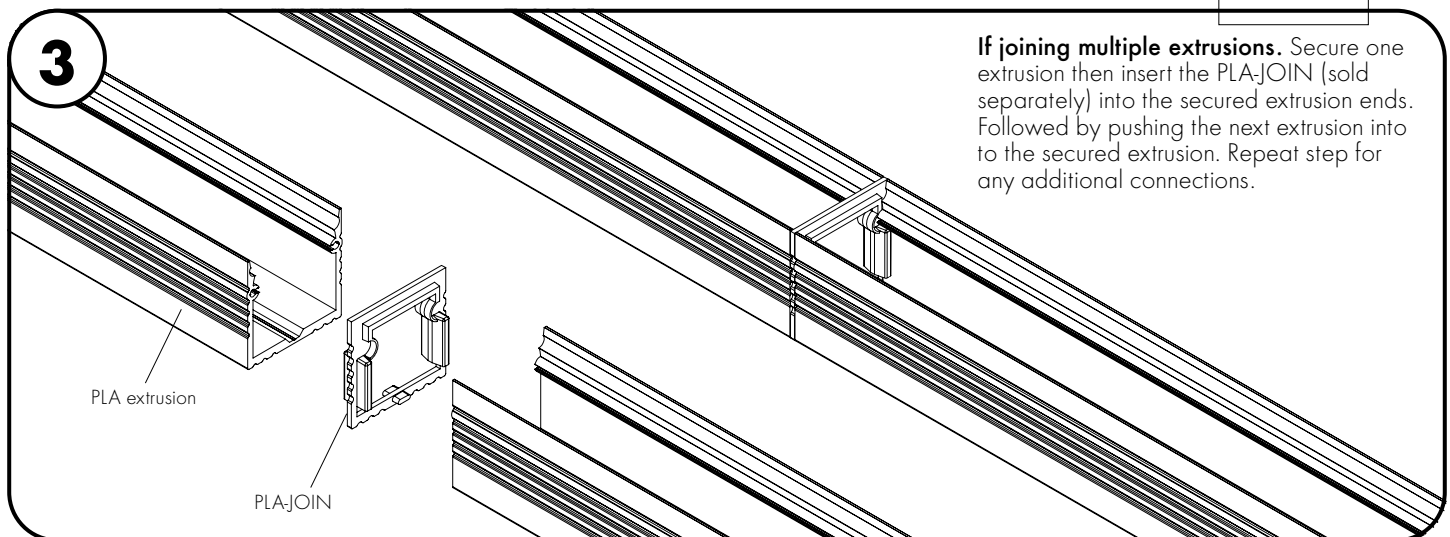
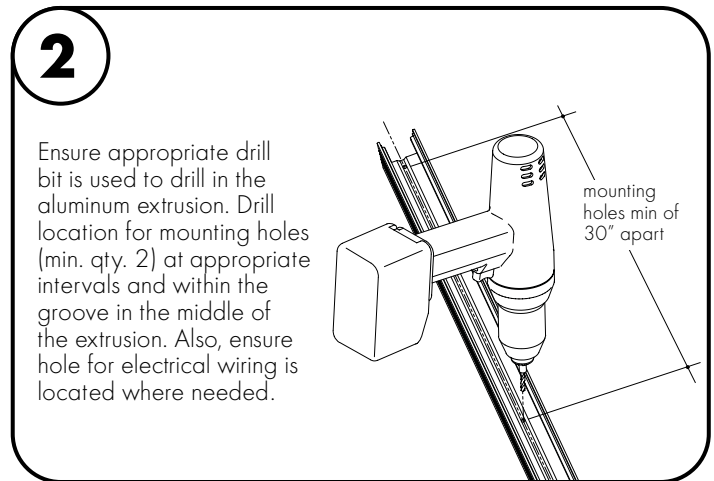
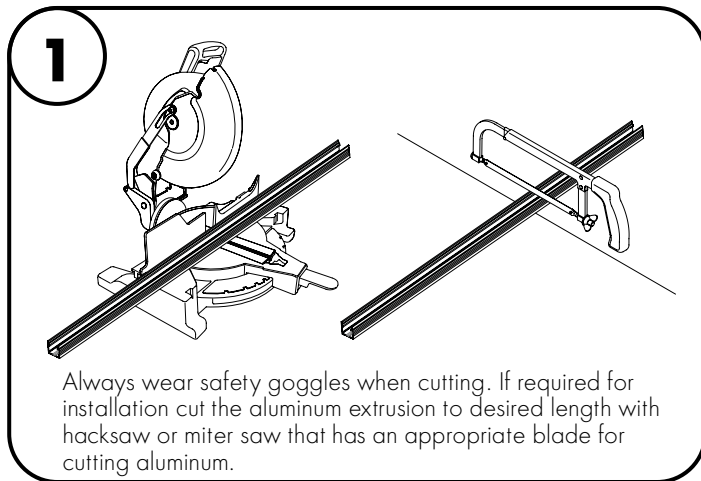

# PLA Channel - Installation Instructions

**Please read all instructions prior to installation and keep for future reference!**

1. Product should be installed by a qualified electrician.
2. Prior to installation ensure power is off at fuse box to prevent electrical shock.
3. If extrusion is installed facing up and in a wet location, ensure proper drainage and silicone endcaps and diffuser lens.

Page 2 of 2

