

# LineLED 24V - Installation Instructions

Models LLRGB42-XX



7777 Merrimac Ave  
Niles, IL 60714  
T 224.333.6033  
F 224.757.7557  
info@luminii.com  
www.luminii.com

REV.0.5  
10082024

1 / 2

Please read all instructions prior to installation and keep for future reference!

1. PRODUCT SHOULD BE INSTALLED BY A QUALIFIED ELECTRICIAN
2. ENSURE POWER IS OFF AT FUSE BOX PRIOR TO INSTALLATION TO PREVENT ELECTRICAL SHOCK
3. USE ONLY WITH CLASS 2 POWER UNIT
4. SUITABLE FOR DAMP LOCATIONS
5. FOR UNDER CABINET OR SHELF MOUNT
6. CONFORMS TO UL STD 2108. CERTIFIED TO CSA STD C22.2 NO.250.0.

**ATTENTION:** ALWAYS TEST LLRGB42 BEFORE INSTALLING. CONNECT LL42-RGB TO POWER SUPPLY TO ENSURE IT IS WORKING PROPERLY AND NO DAMAGE HAS OCCURRED DURING SHIPPING.

**1**

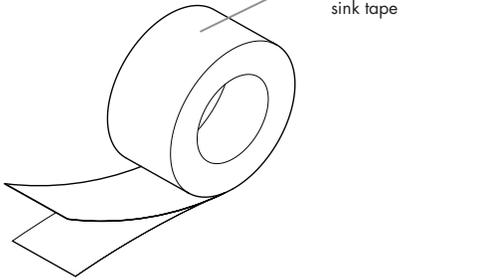

HST - aluminum heat sink tape

**1.1** Clean area thoroughly where tape will be installed.

For rough surface installations, it is recommended to apply a layer of Aluminum tape or similar material prior to tape application.

**2**

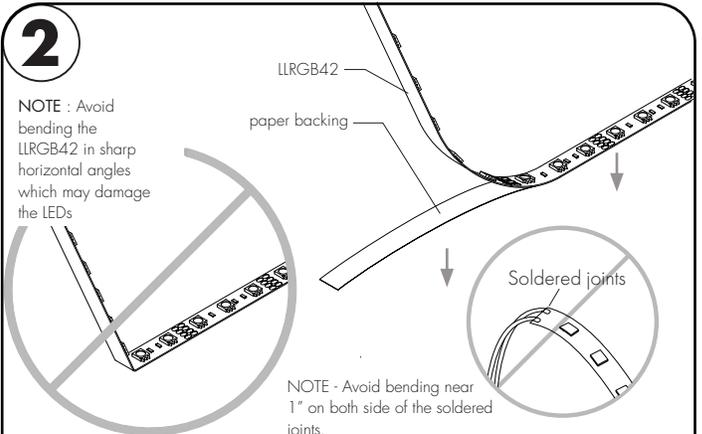

LLRGB42  
paper backing

NOTE : Avoid bending the LLRGB42 in sharp horizontal angles which may damage the LEDs

Soldered joints

NOTE - Avoid bending near 1" on both side of the soldered joints.

**2.1** Remove the paper backing from the LLRGB42 and firmly press down making sure there are no air bubbles that can cause surface irregularities. Do not remove the adhesive, removing the adhesive may cause arcing of the Line LED tape.

**3**

- 3.1** Place the strain relief in desired place. Make sure it is 3" away from the end of the strip.
- 3.2** Slide the ziptie through strain relief opening.
- 3.3** Lay wire lead on top of strain relief.
- 3.4** Tighten zip tie around lead wire. Cut off excess zip tie.

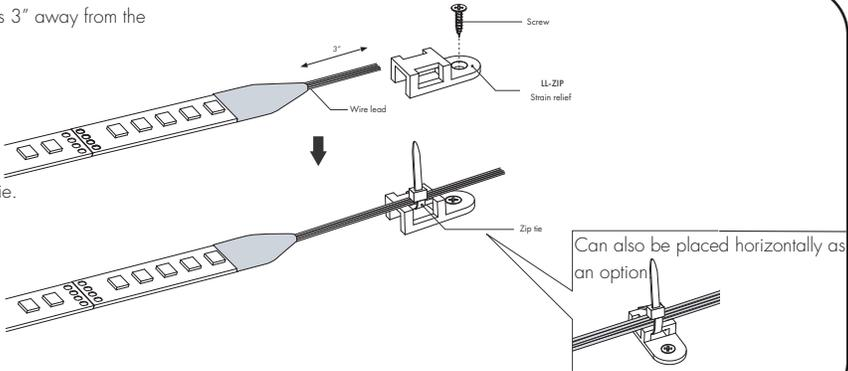

3"  
Wire lead  
Screw  
LL-ZIP Strain relief  
Zip tie

Can also be placed horizontally as an option

**4**

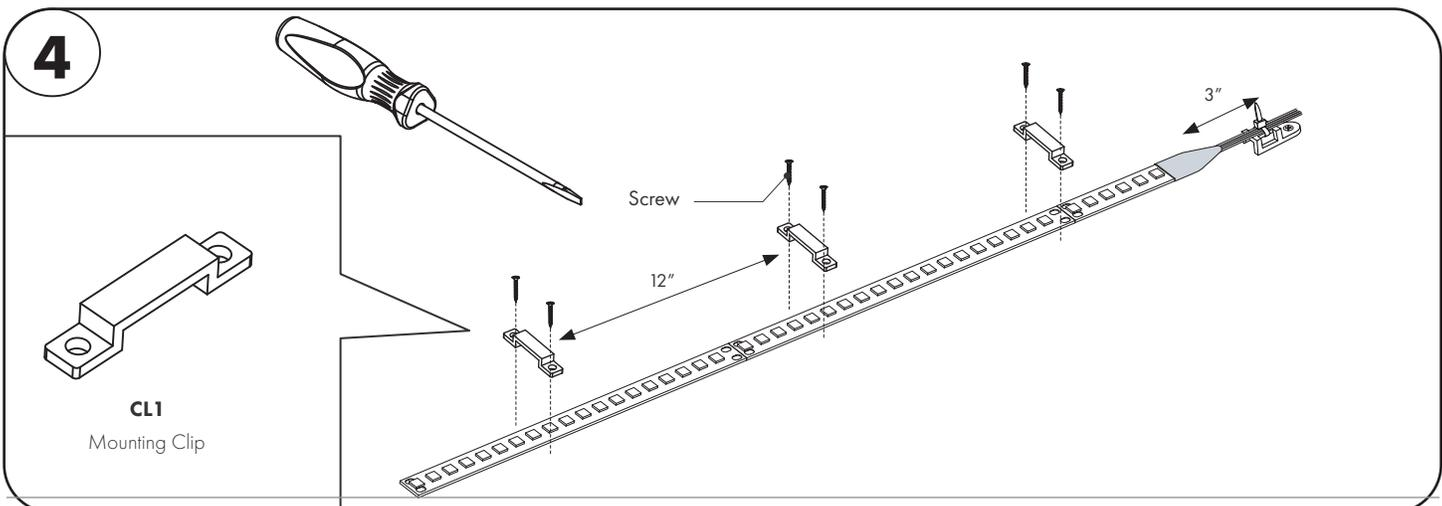

Screw  
12"  
3"  
CL1 Mounting Clip

# LineLED 24V - Installation Instructions

Models LLRGB42-XX



7777 Merrimac Ave  
Niles, IL 60714  
T 224.333.6033  
F 224.757.7557  
info@luminii.com  
www.luminii.com

REVO.5  
10082024

2 / 2

**Please read all instructions prior to installation and keep for future reference!**

1. PRODUCT SHOULD BE INSTALLED BY A QUALIFIED ELECTRICIAN
2. ENSURE POWER IS OFF AT FUSE BOX PRIOR TO INSTALLATION TO PREVENT ELECTRICAL SHOCK
3. USE ONLY WITH CLASS 2 POWER UNIT
4. SUITABLE FOR DAMP LOCATIONS
5. FOR UNDER CABINET OR SHELF MOUNT
6. CONFORMS TO UL STD 2108. CERTIFIED TO CSA STD C22.2 NO.250.0.

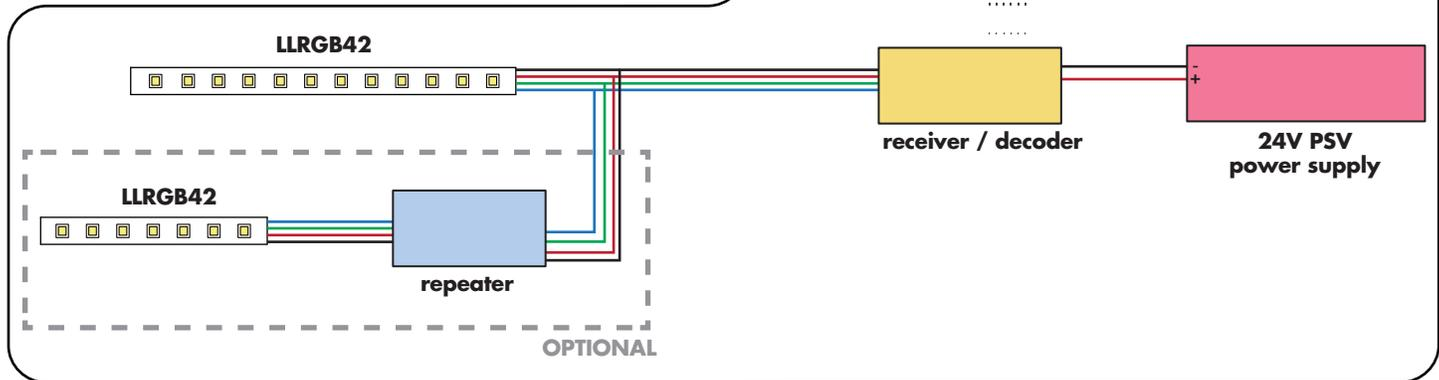
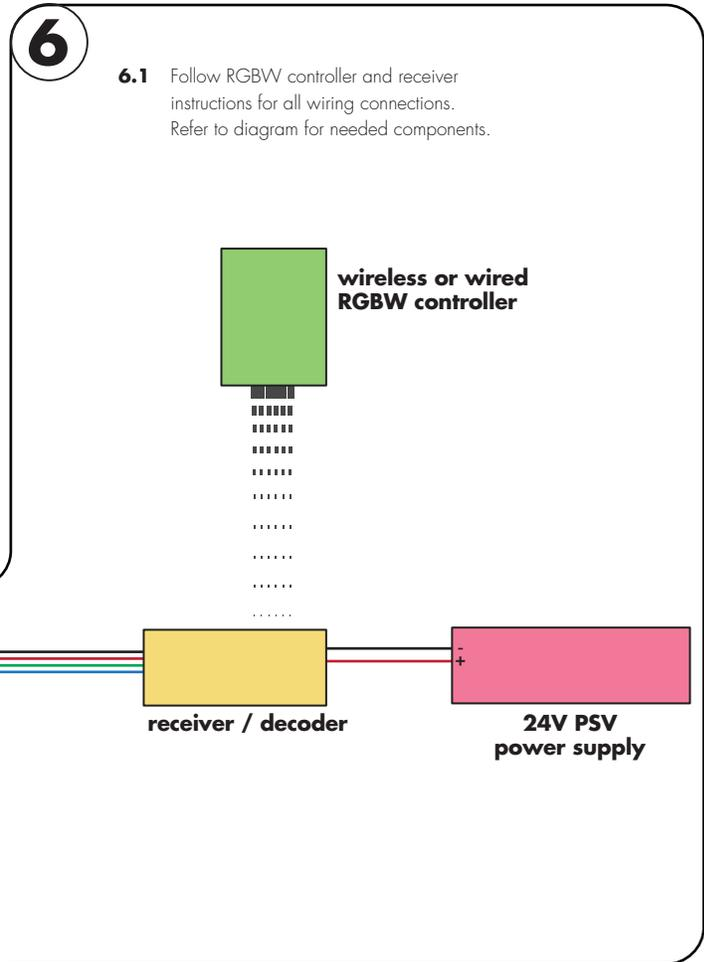
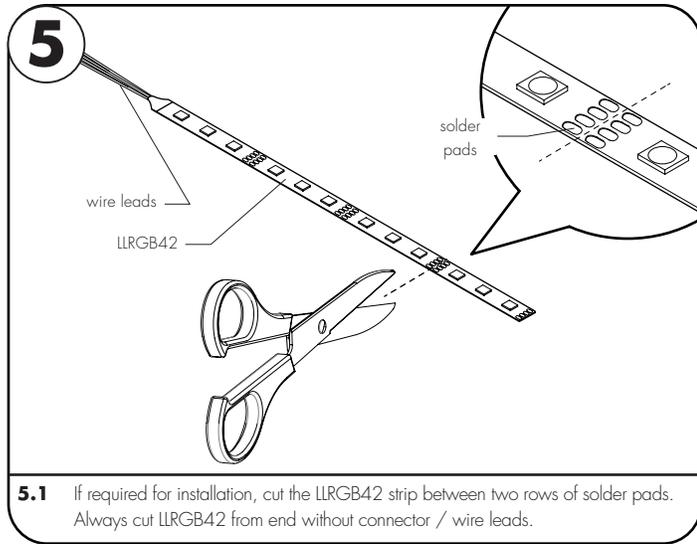

## Power Supply Wiring Diagram

**Note:** Prior to installation all 24VDC wires must be present near fixture. Refer to the power supply installation instructions for additional information.



RGB/RGBW  
Wiring Diagram PDF