

**Features**

Kurba Max is a dot free direct view, highly versatile, energy efficient and flexible LED strip suitable for outdoor wet locations capable of horizontal/side bends and vertical/top bends with a 8" bending radius. The silicone material offers excellent heat, weather, UV, and solvent resistance and has a special coating to repel dust and dirt accumulation.

**Applications**

Indoor/Outdoor dry & wet location

**Average Life (L70)**

50,000 hours

**Materials**

Silicone for red list approved, as well as heat, weather, UV, and solvent resistance

**Approvals**

24VDC Class 2 wet listed, IP68

**Dimming**

Dimable down to 1%. Dot Free even illumination. Also available with Black Lens

**Warranty**

3 years

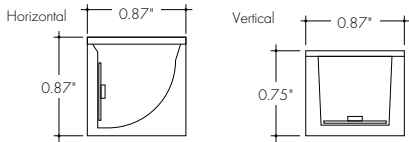

**Finish Options** (see page 2 for additional information)

Base  White

**RoHS Declare.**



**Technical Information**

Bending Direction	Horizontal		Vertical		CCT INFO / LUMEN MULTIPLIER	
	4350	44HO	4350	44HO	Color Temperature	Multiplier (ref. 3000K)
Output	335 lm/ft	437 lm/ft	396 lm/ft	536 lm/ft	2200K	0.93
Light Output at 3000K	5.03 W/ft	5.03 W/ft	5.03 W/ft	5.03 W/ft	2400K	1.00
Average Power Consumption at 4'	67 lm/W	87 lm/W	79 lm/W	107 lm/W	2700K	1.00
Efficacy	1.97"	2.19"	1.97"	2.19"	3000K	1.02
Ordering Increment	19'	19'	19'	19'	3500K	1.02
Maximum Run Length (In Series)	-40°F to 113°F	-40°F to 113°F	-40°F to 113°F	-40°F to 113°F	4000K	1.01
Operating Temperature Range	<b>Note: 80 CRI</b>					

**Constraints**

**Horizontal Bend Direction**

Bend LED in these positions only to avoid damage

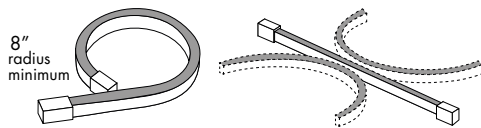

Illuminated surface shown in gray

**Horizontal Prohibited Bends**

Twisting or bending LED in these positions will cause damage

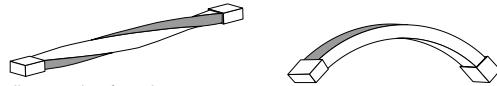

Illuminated surface shown in gray

Do not make sharp bends near the endcap

**Vertical Bend Direction**

Bend LED in these positions only to avoid damage

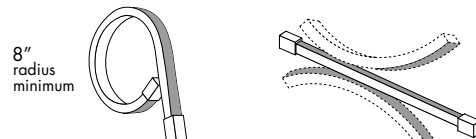

Illuminated surface shown in gray

**Vertical Prohibited Bends**

Twisting or bending LED in these positions will cause damage

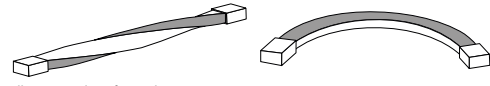

Illuminated surface shown in gray

Do not make sharp bends near the endcap

**Ordering Code**

MODEL	RATING <sup>1</sup>	BEND DIRECTION	LENGTH	OUTPUT <sup>1</sup>	CCT	LENS	MOUNTING	FINISH	FEED POSITION LEFT	FEED POSITION RIGHT
KBX - Kurba Max	W - Wet	HB - Horizontal Bending VB - Vertical Bending	SEE PCC CHART ON PAGES 7 - 8	4350 - Standard 44HO - High	22K - 2200K 27K - 2700K 30K - 3000K 35K - 3500K 40K - 4000K	SF - Silicone Frosted	NA - See Page 6 for orderable mounting accessories	WH - White	INJECTION MOLD IME - End Feed 1 IMB - Back Feed 1 IMSA - Side 1 Feed IMSB - Side 2 Feed <sup>2</sup> NPF - No Power Feed <sup>3</sup>	INJECTION MOLD IME - End Feed 1 IMB - Back Feed 1 IMSA - Side 1 Feed IMSB - Side 2 Feed <sup>2</sup> NPF - No Power Feed <sup>3</sup>

Feeds come with 118" wire leads

1 - Title 24 JA8 compliance achievable, contact factory for specific requests

2 - IMSB - Side 2 Feed not available with HB - Horizontal Bending

3 - NPF-NPF for Feed Position 1&2 is not a valid configuration option

**Powerfeeds and Connectors**

**Power Feed Position Options and Orientation**

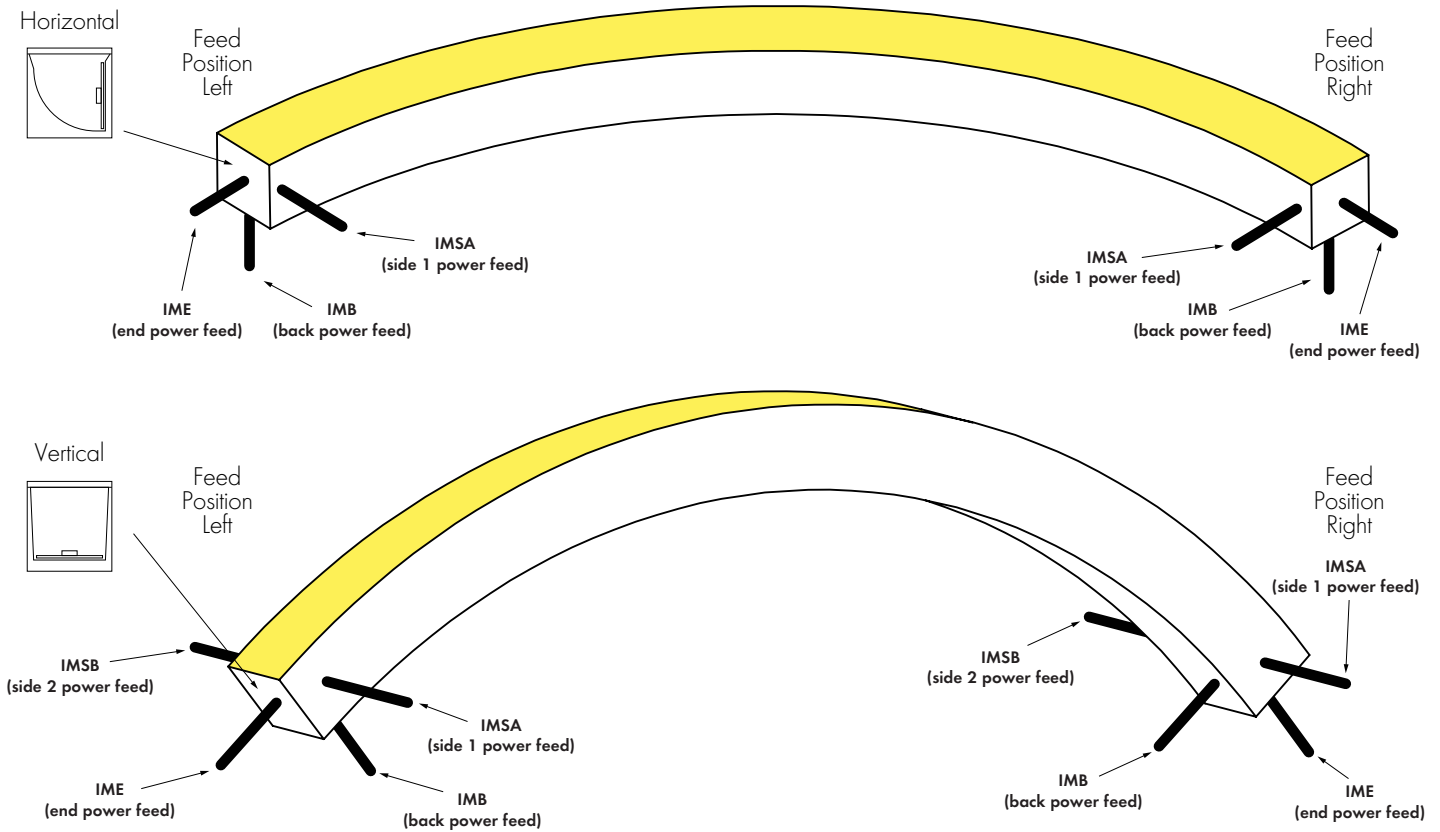

NOTE: IMSB - Side 2 Feed not available with HB - Horizontal Bending

**Powerfeed Options**

**Horizontal**

**END CONNECTOR**

Injection-molded End Connector  
-IME

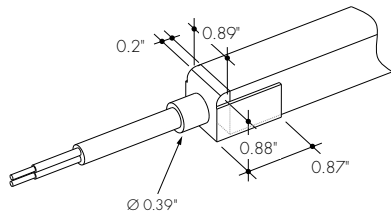

**BACK CONNECTOR**

Injection-molded Back Connector  
-IMB

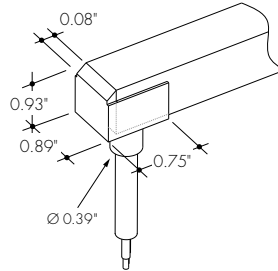

**SIDE CONNECTOR**

Injection-molded Side Connector  
-IMSA

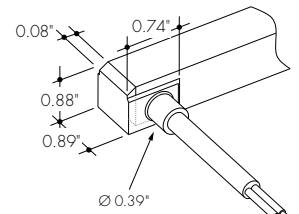

**ENDCAP (NO CONNECTOR)**

Injection-molded Cap (No Connector)  
-NPF

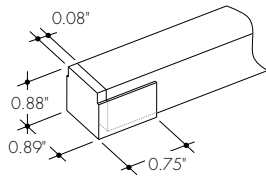

**ANTI-WICKING FERRULE**

Included on every power feed wire

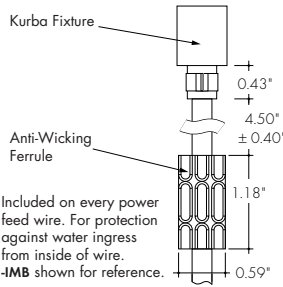

**Vertical**

**END CONNECTOR**

Injection-molded End Connector  
-IME

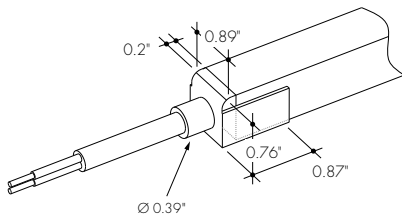

**BACK CONNECTOR**

Injection-molded Back Connector  
-IMB

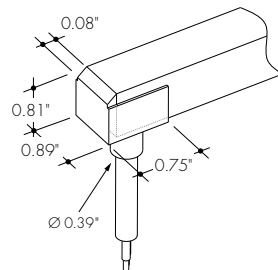

**SIDE CONNECTOR**

Injection-molded Side Connector  
-IMSA and -IMSB

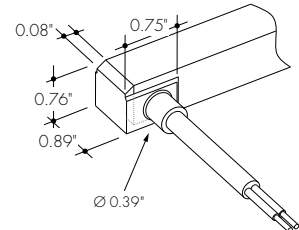

**ENDCAP (NO CONNECTOR)**

Injection-molded Cap (No Connector)  
-NPF

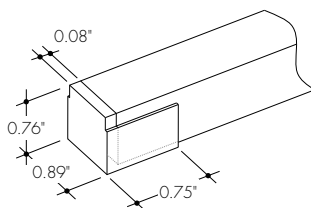

**ANTI-WICKING FERRULE**

Included on every power feed wire

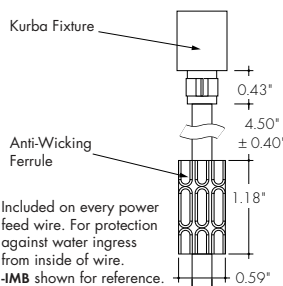

Product Dimensions

Horizontal

Kurba Max Cross Sections

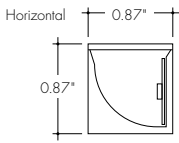

**Example Feed Position**  
IME - NPF  
End Feed 1 to  
No Power Feed

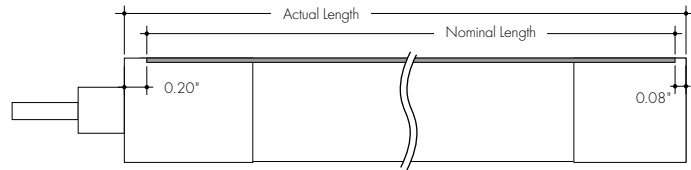
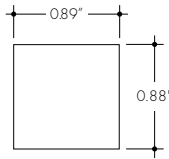

**Example Feed Position**  
IMSA - NPF  
Side 1 Feed to  
No Power Feed

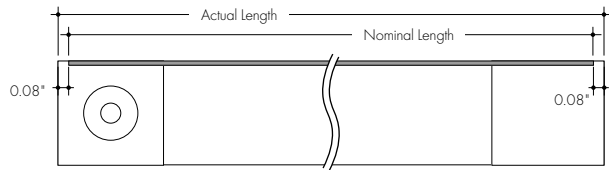
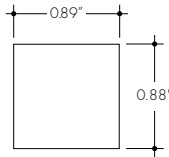

**Example Feed Position**  
IMB - NPF  
Back Feed 1 to  
No Power Feed

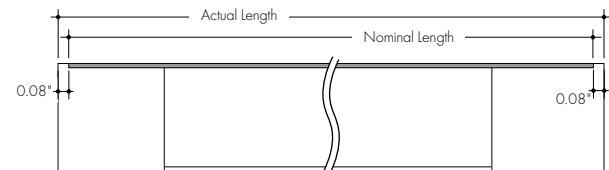
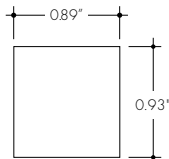

**Example Feed Position**  
IME - IME  
End Feed 1 and  
End Feed 1

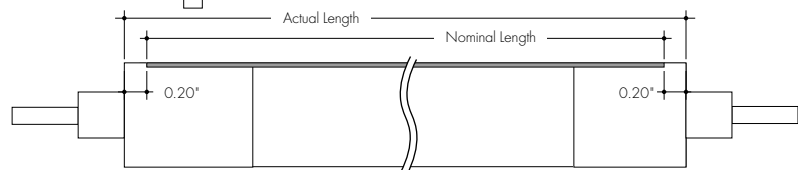
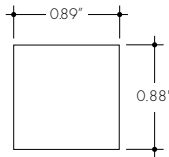

Vertical

Kurba Max Cross Sections

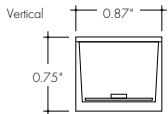

**Example Feed Position**  
IME - NPF  
End Feed 1 to  
No Power Feed

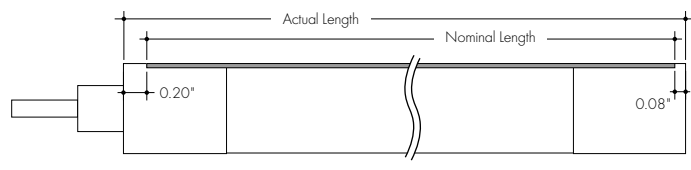
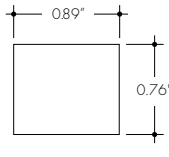

**Example Feed Position**  
IMSA - NPF  
Side 1 Feed to  
No Power Feed

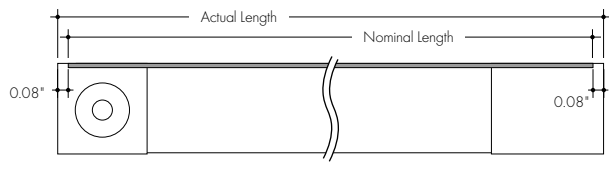
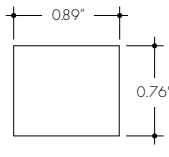

**Example Feed Position**  
IMB - NPF  
Back Feed 1 to  
No Power Feed

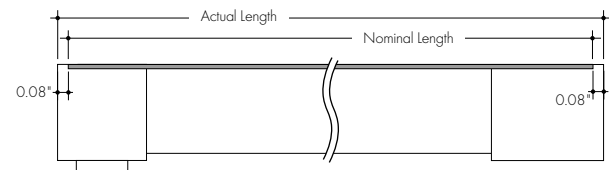
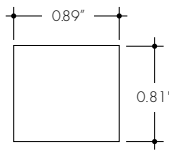

**Example Feed Position**  
IME - IME  
End Feed 1 and  
End Feed 1

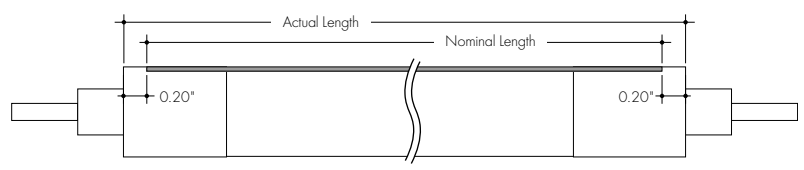
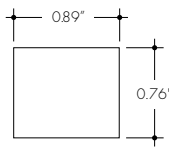

Finish Options

White Base

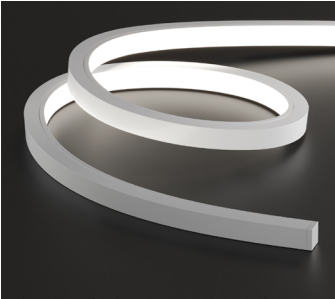

Kurba's base finish is a crisp white which brings a timeless, clean aesthetic that brightens and enhances any space

Light Transmission and Dotting

Output Options	Lens/Accessory
	Silicone Frosted/ White Finish
43SO-HB	ND
44HO-HB	ND
43SO-VB	ND
44HO-VB	ND
<b>Transmission Percentage</b>	100%



CD - Clear Dotting  
SD - Slight Dotting  
ND - No Dotting

Photometry

KBX-W-HB-48-44HO-30K-SF-NA-WH

Kurba Max, Horizontal Bend, 4ft, 3000K, 44HO output, Silicone Frosted Lens

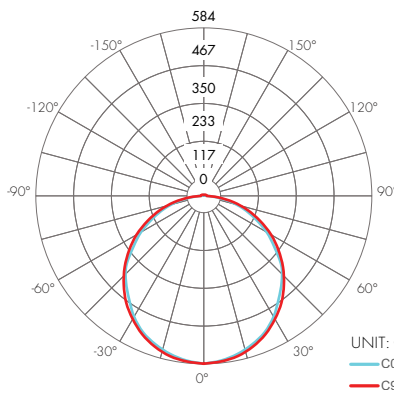

Zonal Lumen Summary 3000K

Zone	Lumen	% Fixture
0-30	452	25.9%
0-40	622	35.6%
0-60	1318	75.4%
0-90	1720	98.4%
0-180	1748	100.0%



KBX-W-VB-48-44HO-30K-SF-NA-WH

Kurba Max, Vertical Bend, 4ft, 3000K, 44HO output, Silicone Frosted Lens

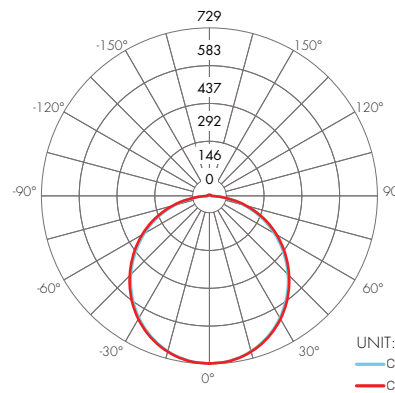

Zonal Lumen Summary 3000K

Zone	Lumen	% Fixture
0-30	562	26.2%
0-40	772	36.0%
0-60	1629	76.0%
0-90	2120	98.9%
0-180	2144	100.0%

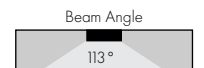

Mounting Accessories

**MC-KBX-SAP-SM-0.8-SA**

KBX Mounting Channel, Serrated Aluminum Profile, Surface Mount, 0.8in, Silver Anodized

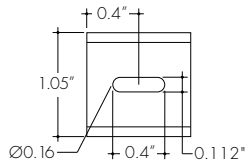
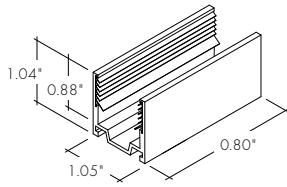

Aluminum mounting bracket providing grip. For use with light strip mounted to the ceiling. 1 recommended every 8 in.

**MC-KBX-SAP-SM-78-SA**

KBX Mounting Channel, Serrated Aluminum Profile, Surface Mount, 78in, Silver Anodized

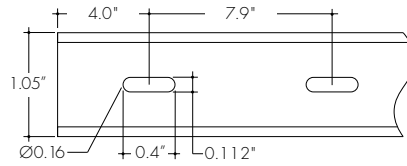
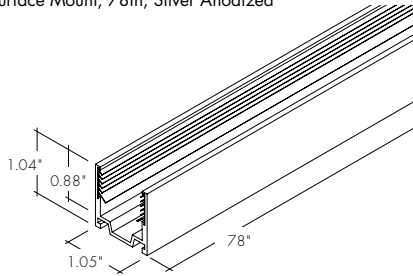

Aluminum mounting channel providing grip. For use with light strip mounted to the ceiling.

**MC-FS-KBL-F-V-78**

Flanged Mounting Channel with grip, 78"

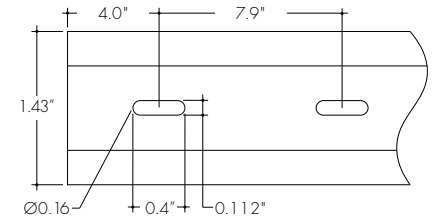
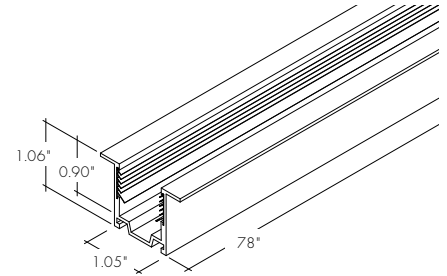

Flanged aluminum mounting channel providing grip. For use with light strip mounted to the ceiling.

**MC-KBX-BSAP-HB-SM-38-SA**

KBX Mounting Channel, Bendable Serrated Aluminum Profile, Horizontal Bending, Surface Mount, 38in, Silver Anodized

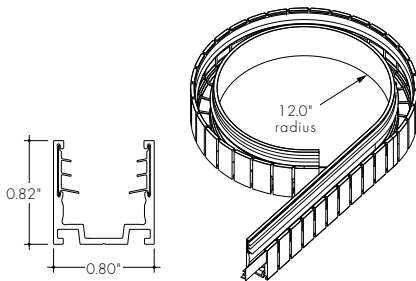

Bendable stainless steel mounting channel providing grip. For use with light strip mounted to the ceiling. **NOTE:** Compatible with HB - Horizontal Bend only

**LVSP-WET**

Splice box: wet rated, low voltage, gray

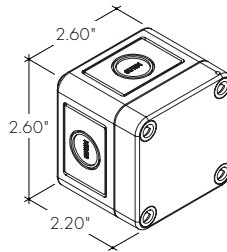

**LVSP-WET-CM**

Connector for splice box, low voltage for cable management, gray

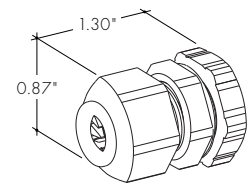

### 43SO | Power Consumption Per Fixture Length

Based on operation with PDCU series of power supplies. Use Actual Length for Order Code Entry.  
 Tolerance for Actual Lengths less than 6 ft is +/- 0.2", Actual Lengths between 6 ft and 16 ft is +/- 0.3", and Actual Lengths greater than 16 ft is +/- 0.6"  
 A - End Connector at both ends of Kurba (0.20" + 0.20" added to overall length)  
 B - End Connector at one end of Kurba and No Connector or Back Connector or Side Connector at other end of Kurba (0.20" + 0.08" added to overall length)  
 C - Any combination of No Connector, Back Connector, or Side Connector on each end of Kurba (0.08" + 0.08" added to overall length)

Nominal Length (in)	Actual Length (in)				Nominal Length (in)	Actual Length (in)				Nominal Length (in)	Actual Length (in)				Nominal Length (in)	Actual Length (in)			
	W	A	B	C		W	A	B	C		W	A	B	C		W	A	B	C
6	2.6	6.3	6.2	6.1	77	32.4	77.2	77.1	76.9	148	62.1	148.0	147.9	147.8	219	91.8	218.9	218.8	218.7
8	3.5	8.3	8.2	8.0	79	33.2	79.1	79.0	78.9	150	62.9	150.0	149.9	149.8	221	92.6	220.9	220.8	220.6
10	4.3	10.2	10.1	10.0	81	34.0	81.1	81.0	80.9	152	63.7	152.0	151.9	151.7	223	93.4	222.8	222.7	222.6
(1FT) 12	5.1	12.2	12.1	12.0	83	34.8	83.1	83.0	82.8	154	64.5	153.9	153.8	153.7	225	94.2	224.8	224.7	224.6
14	5.9	14.2	14.1	13.9	(7FT) 85	35.7	85.0	84.9	84.8	(13FT) 156	65.4	155.9	155.8	155.7	227	95.1	226.8	226.7	226.5
16	6.8	16.1	16.0	15.9	87	36.5	87.0	86.9	86.8	158	66.2	157.9	157.8	157.6	(19 FT) 229	95.9	228.7	228.6	228.5
18	7.6	18.1	18.0	17.9	89	37.3	89.0	88.9	88.7	160	67.0	159.8	159.7	159.6					
20	8.4	20.1	20.0	19.8	91	38.1	91.0	90.8	90.7	162	67.8	161.8	161.7	161.6					
22	9.2	22.1	21.9	21.8	93	39.0	92.9	92.8	92.7	164	68.7	163.8	163.7	163.5					
(2FT) 24	10.1	24.0	23.9	23.8	95	39.8	94.9	94.8	94.6	166	69.5	165.8	165.6	165.5					
26	10.9	26.0	25.9	25.8	(8FT) 97	40.6	96.9	96.7	96.6	(14FT) 168	70.3	167.7	167.6	167.5					
28	11.7	28.0	27.8	27.7	99	41.4	98.8	98.7	98.6	170	71.1	169.7	169.6	169.5					
30	12.5	29.9	29.8	29.7	101	42.3	100.8	100.7	100.6	172	72.0	171.7	171.5	171.4					
32	13.4	31.9	31.8	31.7	103	43.1	102.8	102.6	102.5	174	72.8	173.6	173.5	173.4					
34	14.2	33.9	33.7	33.6	105	43.9	104.7	104.6	104.5	176	73.6	175.6	175.5	175.4					
(3FT) 36	15.0	35.8	35.7	35.6	107	44.7	106.7	106.6	106.5	178	74.4	177.6	177.4	177.3					
38	15.8	37.8	37.7	37.6	(9FT) 109	45.6	108.7	108.5	108.4	(15FT) 180	75.3	179.5	179.4	179.3					
40	16.7	39.8	39.7	39.5	110	46.4	110.6	110.5	110.4	182	76.1	181.5	181.4	181.3					
42	17.5	41.7	41.6	41.5	112	47.2	112.6	112.5	112.4	184	76.9	183.5	183.4	183.2					
44	18.3	43.7	43.6	43.5	114	48.0	114.6	114.5	114.3	185	77.7	185.4	185.3	185.2					
46	19.1	45.7	45.6	45.4	116	48.9	116.5	116.4	116.3	187	78.6	187.4	187.3	187.2					
(4FT) 48	20.0	47.6	47.5	47.4	118	49.7	118.5	118.4	118.3	189	79.4	189.4	189.3	189.1					
50	20.8	49.6	49.5	49.4	(10FT) 120	50.5	120.5	120.4	120.2	191	80.2	191.3	191.2	191.1					
52	21.6	51.6	51.5	51.3	122	51.3	122.4	122.3	122.2	(16FT) 193	81.0	193.3	193.2	193.1					
54	22.4	53.5	53.4	53.3	124	52.2	124.4	124.3	124.2	195	81.9	195.3	195.2	195.0					
56	23.3	55.5	55.4	55.3	126	53.0	126.4	126.3	126.1	197	82.7	197.3	197.1	197.0					
57	24.1	57.5	57.4	57.2	128	53.8	128.4	128.2	128.1	199	83.5	199.2	199.1	199.0					
59	24.9	59.5	59.3	59.2	130	54.6	130.3	130.2	130.1	201	84.3	201.2	201.1	200.9					
(5FT) 61	25.7	61.4	61.3	61.2	(11FT) 132	55.5	132.3	132.2	132.0	203	85.2	203.2	203.0	202.9					
63	26.6	63.4	63.3	63.2	134	56.3	134.3	134.1	134.0	(17FT) 205	86.0	205.1	205.0	204.9					
65	27.4	65.4	65.2	65.1	136	57.1	136.2	136.1	136.0	207	86.8	207.1	207.0	206.9					
67	28.2	67.3	67.2	67.1	138	57.9	138.2	138.1	138.0	209	87.6	209.1	208.9	208.8					
69	29.1	69.3	69.2	69.1	140	58.8	140.2	140.0	139.9	211	88.5	211.0	210.9	210.8					
71	29.9	71.3	71.1	71.0	142	59.6	142.1	142.0	141.9	213	89.3	213.0	212.9	212.8					
(6FT) 73	30.7	73.2	73.1	73.0	(12FT) 144	60.4	144.1	144.0	143.9	215	90.1	215.0	214.8	214.7					
75	31.5	75.2	75.1	75.0	146	61.2	146.1	145.9	145.8	(18 FT) 217	90.9	216.9	216.8	216.7					

Note: All values are rounded to the nearest 0.1 inch.

Endcap (No Connector) -NPF

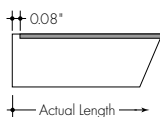

End Connector -IME

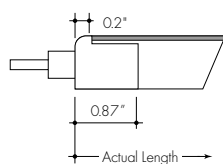

Back Connector -IMB

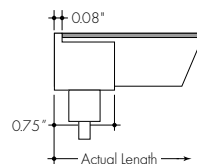

Side Connector -IMSA and -IMSB

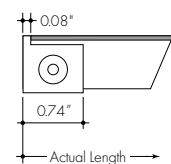

**44HO | Power Consumption Per Fixture Length**

Based on operation with PDCU series of power supplies. Use Actual Length for Order Code Entry.  
 Tolerance for Actual Lengths less than 6 ft is +/- 0.2", Actual Lengths between 6 ft and 16 ft is +/- 0.3", and Actual Lengths greater than 16 ft is +/- 0.6"  
 A - End Connector at both ends of Kurba (0.20" + 0.20" added to overall length)  
 B - End Connector at one end of Kurba and No Connector or Back Connector or Side Connector at other end of Kurba (0.20" + 0.08" added to overall length)  
 C - Any combination of No Connector, Back Connector, or Side Connector on each end of Kurba (0.08" + 0.08" added to overall length)

Nominal Length (in)	Actual Length (in)				Nominal Length (in)	Actual Length (in)				Nominal Length (in)	Actual Length (in)			
	W	A	B	C		W	A	B	C		W	A	B	C
7	2.9	7.0	6.8	6.7	86	35.9	85.7	85.6	85.5	165	68.9	164.5	164.3	164.2
9	3.8	9.1	9.0	8.9	88	36.8	87.9	87.8	87.7	167	69.9	166.6	166.5	166.4
(1 ft) 11	4.8	11.3	11.2	11.1	90	37.8	90.1	90.0	89.8	(14 ft) 169	70.8	168.8	168.7	168.6
14	5.7	13.5	13.4	13.3	92	38.7	92.3	92.2	92.0	171	71.7	171.0	170.9	170.8
16	6.6	15.7	15.6	15.5	95	39.6	94.5	94.3	94.2	173	72.6	173.2	173.1	173.0
18	7.5	17.9	17.8	17.7	(8 ft) 97	40.5	96.6	96.5	96.4	176	73.5	175.4	175.3	175.2
20	8.4	20.1	20.0	19.8	99	41.4	98.8	98.7	98.6	178	74.4	177.6	177.5	177.3
22	9.3	22.3	22.2	22.0	101	42.3	101.0	100.9	100.8	(15 ft) 180	75.4	179.8	179.6	179.5
(2 ft) 24	10.3	24.5	24.3	24.2	103	43.3	103.2	103.1	103.0	182	76.3	182.0	181.8	181.7
27	11.2	26.6	26.5	26.4	106	44.2	105.4	105.3	105.2	184	77.2	184.1	184.0	183.9
29	12.1	28.8	28.7	28.6	(9 ft) 108	45.1	107.6	107.5	107.3	187	78.1	186.3	186.2	186.1
31	13.0	31.0	30.9	30.8	110	46.0	109.8	109.7	109.5	189	79.0	188.5	188.4	188.3
33	13.9	33.2	33.1	33.0	112	46.9	112.0	111.8	111.7	(16 ft) 191	79.9	190.7	190.6	190.5
(3 ft) 35	14.8	35.4	35.3	35.2	114	47.9	114.1	114.0	113.9	193	80.9	192.9	192.8	192.7
38	15.8	37.6	37.5	37.3	116	48.8	116.3	116.2	116.1	195	81.8	195.1	195.0	194.8
40	16.7	39.8	39.7	39.5	119	49.7	118.5	118.4	118.3	198	82.7	197.3	197.1	197.0
42	17.6	42.0	41.8	41.7	(10 ft) 121	50.6	120.7	120.6	120.5	200	83.6	199.5	199.3	199.2
44	18.5	44.1	44.0	43.9	123	51.5	122.9	122.8	122.7	202	84.5	201.6	201.5	201.4
46	19.4	46.3	46.2	46.1	125	52.4	125.1	125.0	124.8	(17 ft) 204	85.4	203.8	203.7	203.6
(4 ft) 49	20.3	48.5	48.4	48.3	127	53.4	127.3	127.1	127.0	206	86.4	206.0	205.9	205.8
51	21.3	50.7	50.6	50.5	130	54.3	129.5	129.3	129.2	208	87.3	208.2	208.1	208.0
53	22.2	52.9	52.8	52.7	(11 ft) 132	55.2	131.6	131.5	131.4	211	88.2	210.4	210.3	210.2
55	23.1	55.1	55.0	54.8	134	56.1	133.8	133.7	133.6	213	89.1	212.6	212.5	212.3
57	24.0	57.3	57.2	57.0	136	57.0	136.0	135.9	135.8	(18 ft) 215	90.0	214.8	214.6	214.5
(5 ft) 60	24.9	59.5	59.3	59.2	138	57.9	138.2	138.1	138.0	217	90.9	217.0	216.8	216.7
62	25.8	61.6	61.5	61.4	141	58.9	140.4	140.3	140.2	219	91.9	219.1	219.0	218.9
64	26.8	63.8	63.7	63.6	143	59.8	142.6	142.5	142.3	222	92.8	221.3	221.2	221.1
66	27.7	66.0	65.9	65.8	(12 ft) 145	60.7	144.8	144.6	144.5	224	93.7	223.5	223.4	223.3
68	28.6	68.2	68.1	68.0	147	61.6	147.0	146.8	146.7	226	94.6	225.7	225.6	225.5
70	29.5	70.4	70.3	70.2	149	62.5	149.1	149.0	148.9	(19 ft) 228	95.5	227.9	227.8	227.6
(6 ft) 73	30.4	72.6	72.5	72.3	152	63.4	151.3	151.2	151.1					
75	31.3	74.8	74.7	74.5	154	64.4	153.5	153.4	153.3	Note: All values are rounded to the nearest 0.1 inch.				
77	32.3	77.0	76.8	76.7	(13 ft) 156	65.3	155.7	155.6	155.5					
80	33.2	79.1	79.0	78.9	158	66.2	157.9	157.8	157.7					
81	34.1	81.3	81.2	81.1	160	67.1	160.1	160.0	159.8					
(7 ft) 84	35.0	83.5	83.4	83.3	162	68.0	162.3	162.1	162.0					

Endcap (No Connector) -NPF

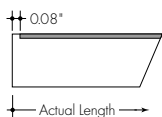

End Connector -IME

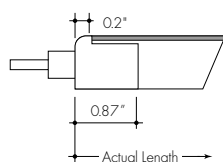

Back Connector -IMB

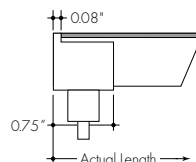

Side Connector -IMSA and -IMSB

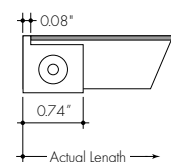



**Power Supplies**

See Power Supply instructions and spec sheet for wiring information. For a complete list of compatible dimmers, see Compatible Dimming Chart on the Resources page.

**For use with Static White**

**Ordering Code Universal Dimming Power Supplies 1% 120VAC - 277VAC**

MODEL	INPUT CONTROL	ENVIRONMENT	WATTAGE	OUTPUT
PS-Power Supply, 120-277VAC	UNI-0-10V Dimming, Phase Dimming	D-Dry W-Wet	30-30 Watts 60-60 Watts 96-96 Watts 3x96-3x96 Watts	24-24 VDC

Compatibility: View a complete list of compatible dimmers on product page [Link](#)

0-10V - 1% dimming  
MLV/ELV/TRIAC - 1% dimming, consult dimming compatibility chart

MODELS	PS-UNI-W-30W	PS-UNI-W-60W	PS-UNI-W-96W	PS-UNI-W-3X96W
<b>Length</b>	6.50"	7.40"	8.66"	11.85"
<b>Width</b>	3.73"	3.73"	3.73"	4.32"
<b>Depth</b>	1.61"	1.61"	1.61"	1.81"

MODELS	PS-UNI-D-30W	PS-UNI-D-60W	PS-UNI-D-96W	PS-UNI-D-3X96W
<b>Length</b>	8.77"	8.77"	8.11"	9.94"
<b>Width</b>	4.27"	4.27"	5.60"	7.61"
<b>Depth</b>	1.83"	1.83"	1.83"	2.02"

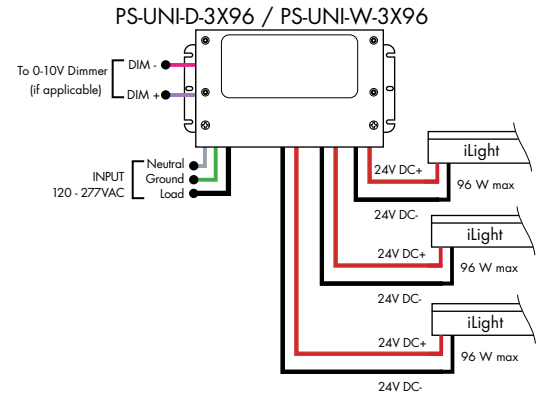
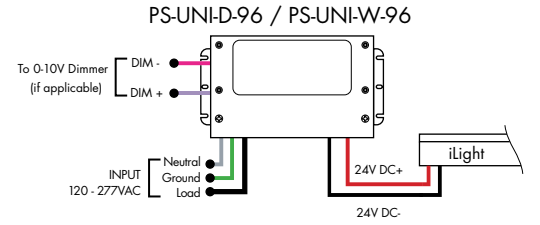

**For use with Static White**

**0-10V Dimming Power Supplies 0.1% 120VAC - 277VAC**

MODEL	POWER	OUTPUT	INPUT CONTROL	ENVIRONMENT
PS-Power Supply, 120-277VAC	96-96 Watts 3x96-3x96 Watts	24-24 VDC	010V-LIN-0-10V Dimming (0.1%), Linear 010V-LOG-0-10V Dimming (0.1%), Logarithmic	D-Dry

MODELS	96W	3X96
<b>Length</b>	14.40"	15.00"
<b>Width</b>	5.20"	6.62"
<b>Depth</b>	2.60"	4.45"

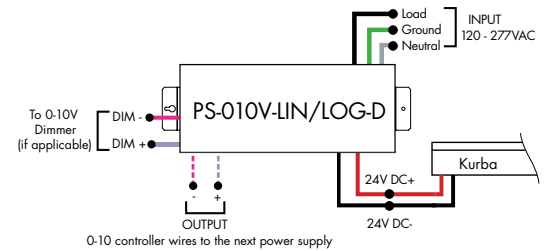
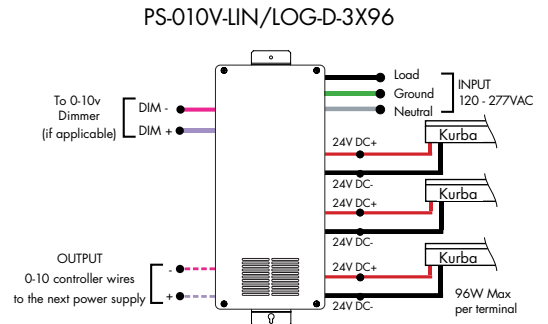

## Power Supplies

See Power Supply instructions and spec sheet for wiring information. For a complete list of compatible dimmers, see Compatible Dimming Chart on the Resources page.

### For use with Static White

#### Athena 0-10V LED Driver

MODEL	INPUT CONTROL	ENVIRONMENT	WATTAGE	OUTPUT	FEATURE
PS-Power Supply, 120-277VAC	010V-LIN-0-10V Dimming (0.1%), Linear 010V-LOG-0-10V Dimming (0.1%), Logarithmic	D-Dry	96-96 Watts	24-24 VDC	AWN-R-Athena

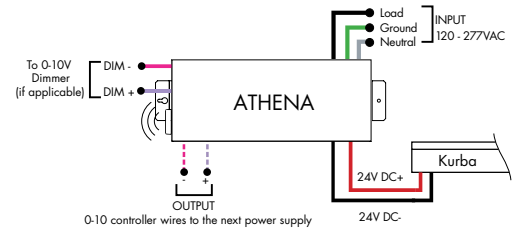

MODELS	96W
Length	14.40"
Width	5.20"
Depth	2.60"

### For use with Static White

#### Ordering Code Phase Dimming Power Supply 1% 120VAC - 277VAC

MODEL	INPUT CONTROL	ENVIRONMENT	WATTAGE	OUTPUT	OUTPUT CONTROL
PS-Power Supply, 120-277VAC	PH-Phase Dimming (Triac, ELV, MLV)	D-Dry	96-96 Watts	24-24 VDC	DC-Direct Current

MLV/ELV/TRIAC - 1% dimming, consult dimming compatibility chart ([link](#))

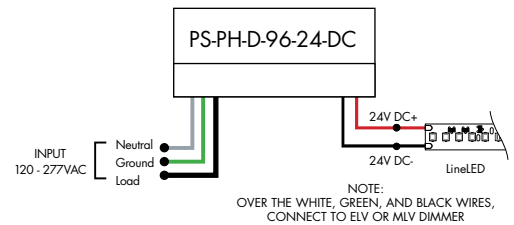

MODELS	96W
Length	8.25"
Width	4.10"
Depth	1.56"

### For use with Static White

#### DALI Dimming Power Supplies 0.1% 120VAC - 277VAC

MODEL	INPUT CONTROL	ENVIRONMENT	WATTAGE	OUTPUT
PS-Power Supply, 120-277VAC	DALI-DALI (0.1%)	D-Dry	96-96 Watts 3x96-3x96 Watts	24-24 VDC

Model	96W	3X96
Length	14.40"	15.00"
Width	5.20"	6.62"
Depth	2.60"	4.56"

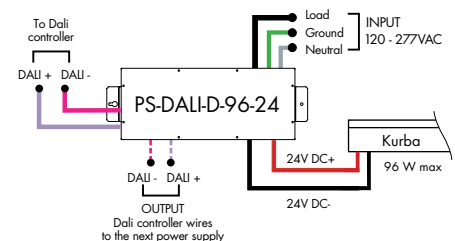
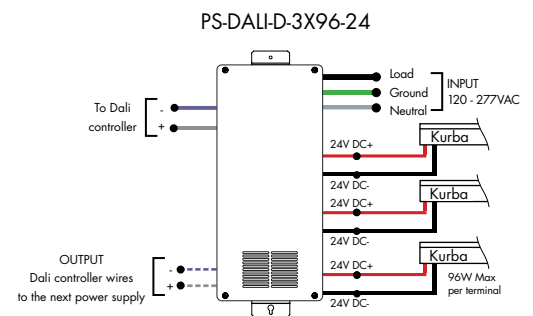

**Power Supplies**

See Power Supply instructions and spec sheet for wiring information. For a complete list of compatible dimmers, see Compatible Dimming Chart on the Resources page.

**For use with Static White**

**Athena 0-10V LED Driver**

MODEL	INPUT CONTROL	ENVIRONMENT	WATTAGE	OUTPUT	FEATURE
PS-Power Supply, 120-277VAC	010V-0-10V Dimming (1%)	D-Dry	96-96 Watts	24-24 VDC	ENL-0-10V Enlightened

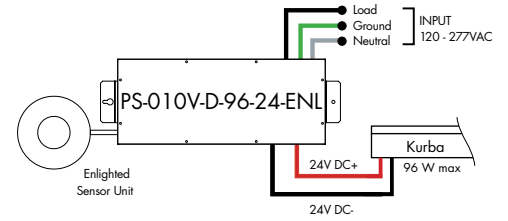

<b>Model</b>	<b>96W</b>
<b>Length</b>	14.40"
<b>Width</b>	5.20"
<b>Depth</b>	2.60"

**For use with Static White**

Requires Zonal Control

**DMX Dimming Power Supplies 0.1% 120VAC - 277VAC**

MODEL	INPUT CONTROL	ENVIRONMENT	WATTAGE	OUTPUT
PS-Power Supply, 120-277VAC	DMX-DMX (0.1%)	D-Dry	96-96 Watts 3x96-3x96 Watts	24-24 VDC

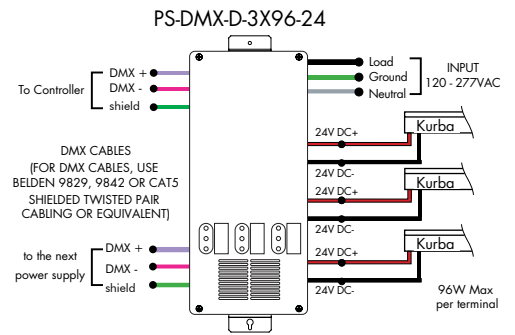

MODELS	96W	3X96
<b>Length</b>	14.40"	15.00"
<b>Width</b>	5.20"	6.62"
<b>Depth</b>	2.60"	4.56"

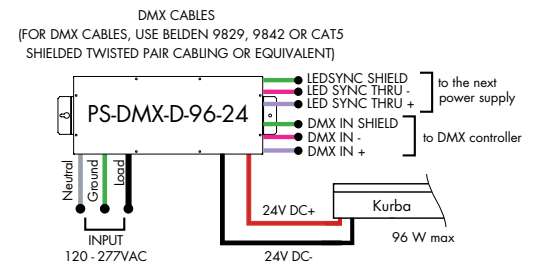

**For use with Static White**

**DMX Dimming Power Supplies 0.1% 120VAC - 277VAC**

MODEL	INPUT CONTROL	ENVIRONMENT	WATTAGE	OUTPUT
PS-Power Supply, 120-277VAC	ND-Non Dimming	D-Dry	96-96 Watts	24-24 VDC

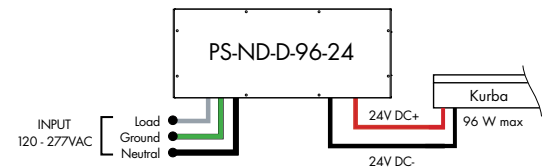

<b>MODELS</b>	<b>96W</b>
<b>Length</b>	14.40"
<b>Width</b>	5.20"
<b>Depth</b>	2.60"

## Power Supplies

See Power Supply instructions and spec sheet for wiring information. For a complete list of compatible dimmers, see Compatible Dimming Chart on the Resources page.

### For use with Static White

#### In-Ground Power Supplies

MODEL	INPUT CONTROL	ENVIRONMENT	WATTAGE	OUTPUT
PS120	ELV-ELV Dimming (1%)	IG-In Ground	2X96-2X96 Watts	24-24 VDC
PS120-Power Supply, 120VAC PS240-Power Supply, 240VAC PS277-Power Supply, 277VAC				

#### MODELS 2X96W

<b>Length</b>	8.40"
<b>Width</b>	8.30"
<b>Depth</b>	8.10"

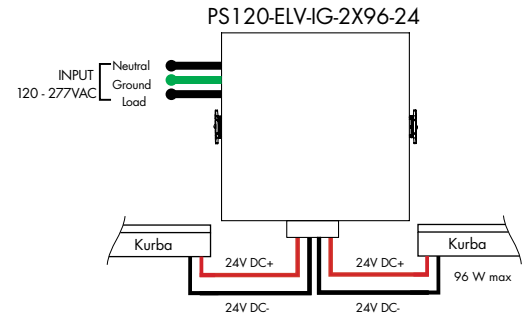

Luminii is a Lutron OEM Advantage Partner

#### Lutron Power Supplies 1%

##### MODEL

**L3DA4U1UKL-CV240**

HiLume™ 1% EcoSystem Voltage LED driver  
40W max

#### MODELS L3DA4U1UKL-CV240

<b>Length</b>	4.98"
<b>Width</b>	4.00"
<b>Depth</b>	2.62"

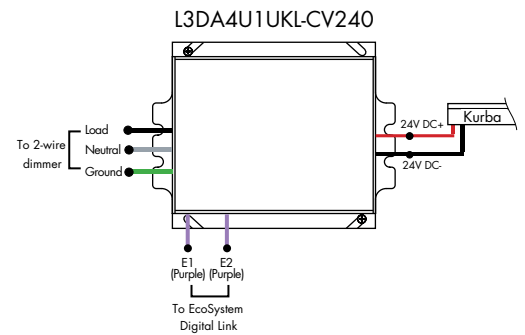

Luminii is a Lutron OEM Advantage Partner

#### Lutron Power Supplies 0.1%

##### MODEL

**L3D0-96W24V-U**

HiLume™ 0.1% EcoSystem Voltage LED Driver with Soft-On, Fade-to-Black™  
96W max

#### MODELS L3D0

<b>Length</b>	10.50"
<b>Width</b>	5.50"
<b>Depth</b>	2.00"

