

CLA Channel - Installation Instructions

Models CLAC-XX-S-XX & CLAC-XX-Q-XX



7777 Merrimac Ave
Niles, IL 60714
T 224.333.6033
F 224.757.7557
info@luminii.com
www.luminii.com

Please read all instructions prior to installation and keep for future reference!

1. Product to be installed by a qualified electrician.
2. Prior to installation ensure power is off at fuse box to prevent electrical shock.
3. Fixture should be installed by two people.

Page 1 of 2

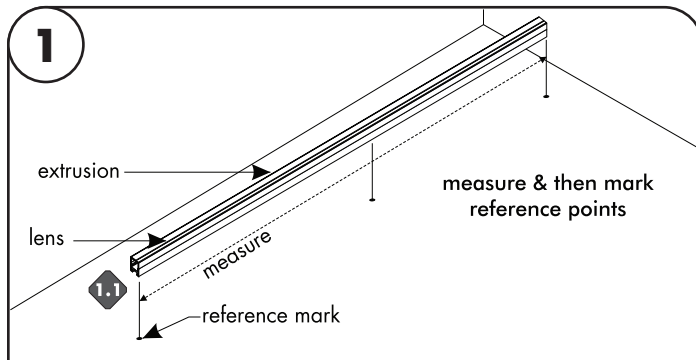

Note: Complete fixture must be built prior to installing, to properly make all necessary reference marks & to ensure all parts are included. Then it can be taken apart for installation.

- 1.1 Snap the lens into the extrusion, then align & center the extrusion to the determined location. Make all necessary markings to install to the surface.

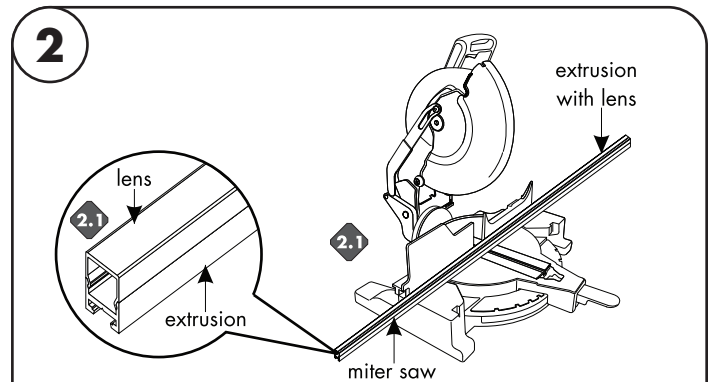

Caution: Safety equipment is recommended, when modifications are being made to the extrusion & lens.

- 2.1 If necessary extrusion with the lens installed can be cut in the field. Use the proper blade for aluminum, and then cut to the desired length.

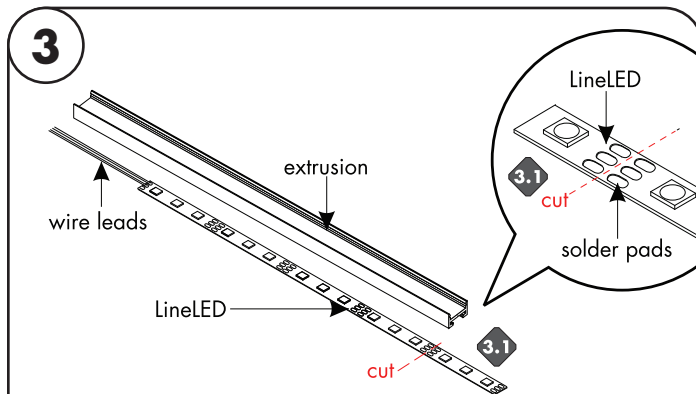

- 3.1 LineLED can be shortened by cutting along the dashed lines in between the solder pads. Make sure the cut is made on the side of the LineLED without the wire leads. LineLED cannot touch the metal endcaps which will shorten the circuit.

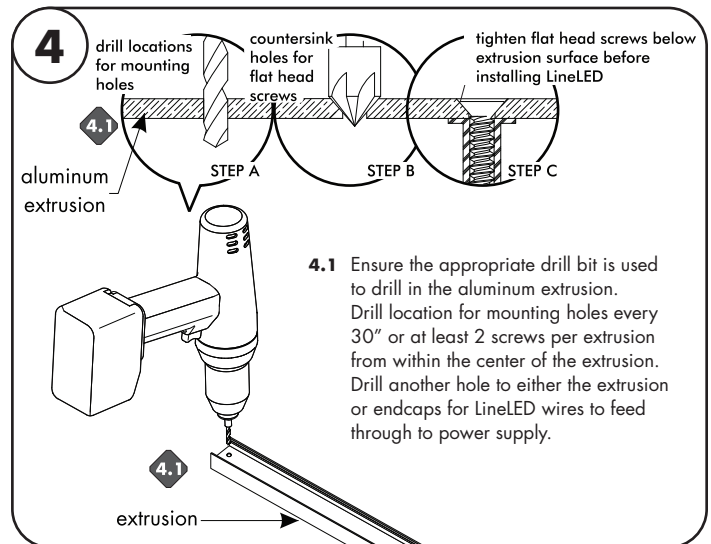

- 4.1 Ensure the appropriate drill bit is used to drill in the aluminum extrusion. Drill location for mounting holes every 30" or at least 2 screws per extrusion from within the center of the extrusion. Drill another hole to either the extrusion or endcaps for LineLED wires to feed through to power supply.

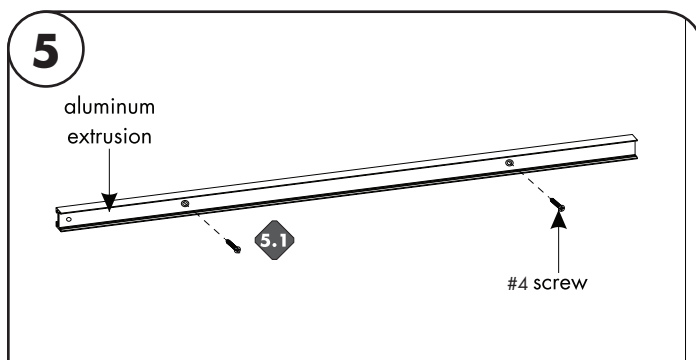

- 5.1 Secure the extrusion directly to wall with the appropriate hardware.

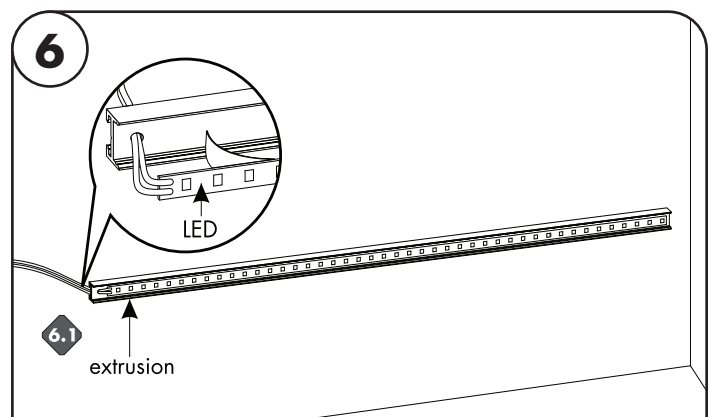

- 6.1 Clean extrusion from any debris.
- 6.2 If applicable, feed LineLED wires through the extrusion hole. Remove the paper backing from the adhesive tape on the LineLED before installing the extrusion.

CLA Channel - Installation Instructions

Models CLAC-XX-S-XX & CLAC-XX-Q-XX



7777 Merrimac Ave
Niles, IL 60714
T 224.333.6033
F 224.757.7557
info@luminii.com
www.luminii.com

Please read all instructions prior to installation and keep for future reference!

1. Product to be installed by a qualified electrician.
2. Prior to installation ensure power is off at fuse box to prevent electrical shock.
3. Fixture should be installed by two people.

Page 2 of 2

