

BOS Channel - Installation Instructions

Models BOSC-XX



7777 Merrimac Ave
Niles, IL 60714
T 224.333.6033
F 224.757.7557
info@luminii.com
www.luminii.com

Please read all instructions prior to installation and keep for future reference!

1. Product to be installed by a qualified electrician.
2. Prior to installation ensure power is off at fuse box to prevent electrical shock.
3. Fixture should be installed by two people.

Page 1 of 2

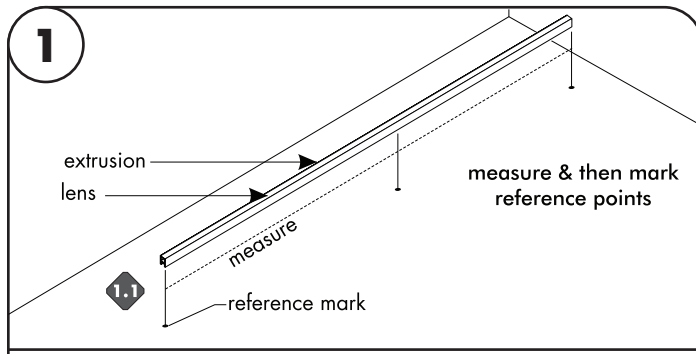

Note: Complete fixture must be built prior to installing, to properly make all necessary reference marks & to ensure all parts are included. Then it can be taken apart for installation.

- 1.1** Snap lens into the extrusion, then align & center the extrusion to the determined location. Make all necessary markings to install to the surface. Prior to installation of extrusion, 24VDC power must be present.

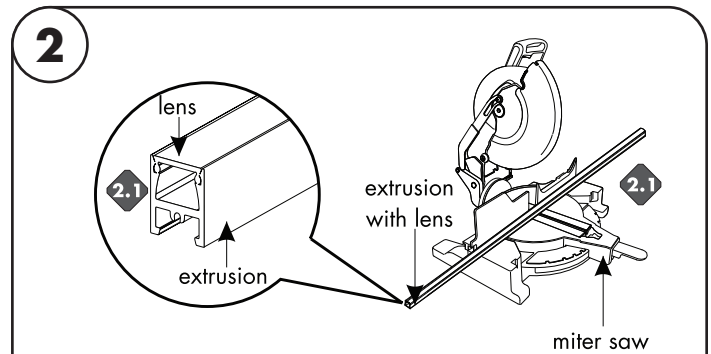

Caution: Safety equipment is recommended, when modifications are being made to the extrusion & lens.

- 2.1** If necessary extrusion, lens, & mounting channel (if applicable) can be cut in the field. Snap all parts together then using the proper blade for aluminum cut to the desired length.

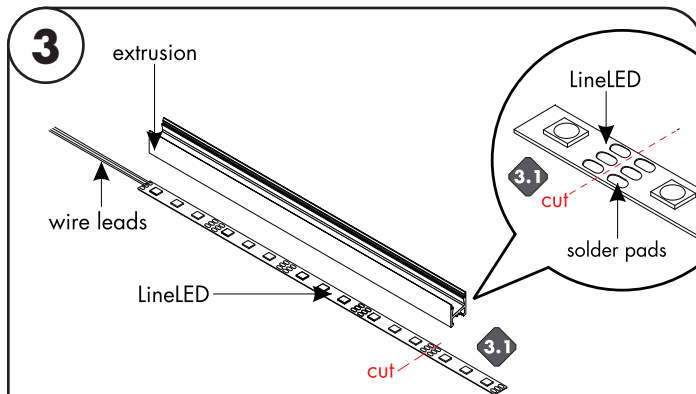

- 3.1** LineLED can be shortened by cutting along the dashed lines in between the solder pads. Make sure the cut is made on the side of the LineLED without the wire leads. LineLED cannot touch the metal endcap which will shorten the circuit.

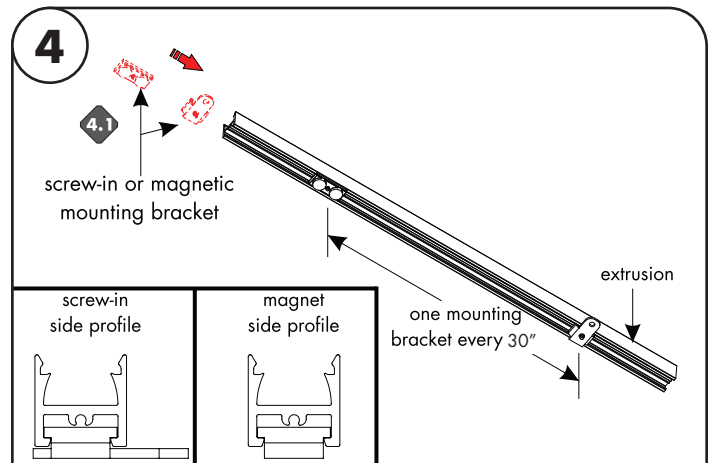

- 4.1** If using a magnetic or screw-in mounting bracket slide through the side of the extrusion followed by tightening the set screw on the bracket.

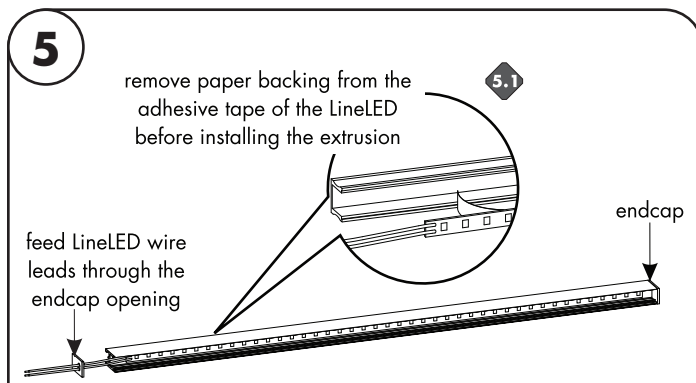

- 5.1** Prior to installing LineLED to extrusion, clean extrusion from any debris. Gently push LineLED onto aluminum extrusion. Then install endcaps at each ends of the extrusion.

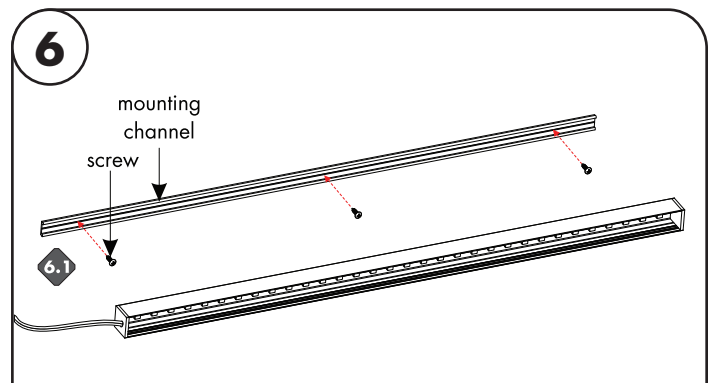

- 6.1** If using the mounting channel option lay onto the wall and secure using the provided screws.

BOS Channel - Installation Instructions

Models BOSC-XX



7777 Merrimac Ave
Niles, IL 60714
T 224.333.6033
F 224.757.7557
info@luminii.com
www.luminii.com

Please read all instructions prior to installation and keep for future reference!

1. Product to be installed by a qualified electrician.
2. Prior to installation ensure power is off at fuse box to prevent electrical shock.
3. Fixture should be installed by two people.

Page 2 of 2

7

Labels: #4 screw, mounting channel, extrusion, 7.1a

7.1b

Labels: mounting bracket, extrusion, screw, 7.1b

screw-in bracket side profile	magnet bracket side profile
	metal

7.1a If using the mounting channel option, lay channel onto the wall and secure using the provided screws. Then snap extrusion onto the mounting channel to secure in place.

7.1b If using a magnetic bracket, place onto a metal surface.

7.1c If using a mounting bracket place on the mounting surface and secure by tightening a screw through the bracket, and repeat for any remaining brackets.

8

Labels: extrusion, lens, protective film, 8.1

8.1 Remove the protective film from the diffuser lens. Snap the diffuser lens into the aluminum extrusion.

9

Labels: class II power supply, LineLED of extrusion, line voltage wires, low voltage wires, 9.1

9.1 Ensure the correct (wattage & voltage) power supply is used to power LineLED. Then proceed to connect LineLED wires from extrusion to power supply. For more information please refer to power supply and LineLED wiring instructions.