

Power Supply Wiring Diagram - PIXEL

Models: PS-XX



7777 Merrimac Ave
Niles, IL 60714
T 224.333.6033
F 224.757.7557
info@luminii.com
www.luminii.com

Please read all instructions prior to installation and keep for future reference!

1. PRODUCT TO BE INSTALLED BY A QUALIFIED ELECTRICIAN.
2. DMX ADDRESSING, PROGRAMMING, AND CONTROL IS REQUIRED AND TO BE PROVIDED BY OTHERS

REVO.1
10062024

1 / 2

SPI RGBW PIXEL WIRING DIAGRAM

SR-DMX-SPI

DMX Termination

SPI Decoder

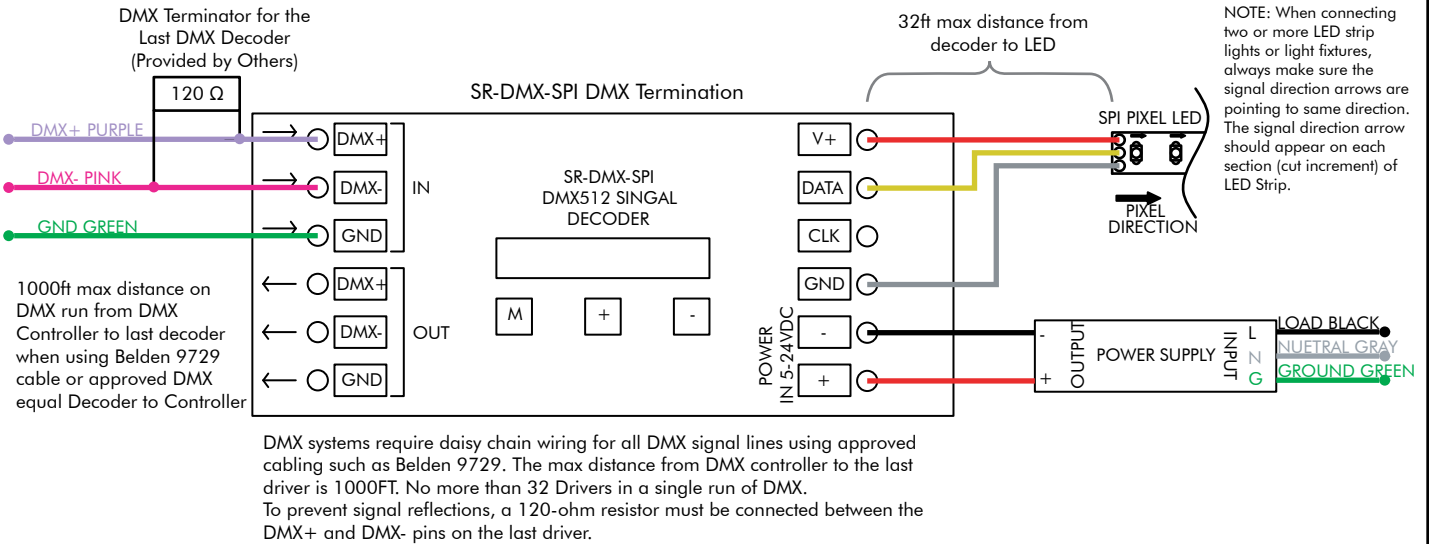

NOTE

NOTE: When connecting two or more LED strip lights or light fixtures, always make sure the signal direction arrows are pointing to same direction

The signal direction arrow should appear on each section (cut increment) of LED strip

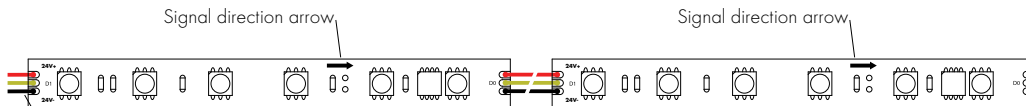

NOTE: Must power from the opposite direction of the signal direction arrow

Power Supply Wiring Diagram - PIXEL

Models: PS-XX

Please read all instructions prior to installation and keep for future reference!

1. PRODUCT TO BE INSTALLED BY A QUALIFIED ELECTRICIAN.
2. DMX ADDRESSING, PROGRAMMING, AND CONTROL IS REQUIRED AND TO BE PROVIDED BY OTHERS

REVO.1
10062024

2 / 2



7777 Merrimac Ave
Niles, IL 60714
T 224.333.6033
F 224.757.7557
info@luminii.com
www.luminii.com

PIXEL DECODER CHAIN WIRING DIAGRAM EXAMPLE

