

Enlightened Dimming LED Driver 96 Watt - Installation Instructions

Models PSV-96-24-ENL-D

Please read all instructions prior to installation and keep for future reference!

This power supply is to be installed in accordance with Article 450 of the National Electrical Code. The power supply must be installed in a well ventilated area and free from explosive gases and vapors. Proper operation requires the free flow of air. As this power supply is hardwired, it should be installed by a qualified electrician. UL class 2 recognized



REVO.6
04302024



7777 Merrimac Ave
Niles, IL 60714
T 224.333.6033
F 224.757.7557
info@luminii.com
www.luminii.com

1 / 2

Input	120 - 277 V AC, 1.1 A, 50/60 Hz
Output	24 V DC, 4.0 A
Max. Wattage	96 W

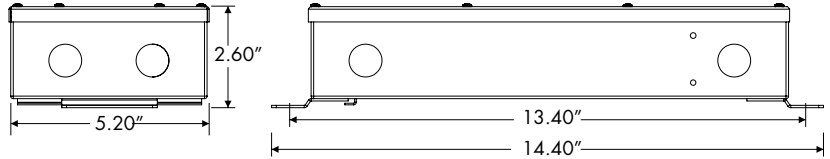

1

Before installing, check the label and ensure the LED Driver has the proper input voltage, output voltage, and wattage for the job. Check the wire markings to ensure they match the wiring diagram below. Refer to table above for the maximum loads!

1.1 LED Driver can be mounted vertically or horizontally. With a minimum of 3" clearance around LED Driver to provide proper air circulation.

2

2.1 Remove the eight Phillips screws from the top of the driver housing and pull the cover off to expose the driver wires.

3

3.1 Insert the 120-277V AC power into the driver housing from the electrical panel. Followed by bringing 24V DC low voltage conduit one for the LED & other for controller wires. Refer to diagram on page 2 to make all the proper wiring connections.

Enlightened Dimming LED Driver 96 Watt - Installation Instructions

Models PSV-96-24-ENL-D

Please read all instructions prior to installation and keep for future reference!

This power supply is to be installed in accordance with Article 450 of the National Electrical Code. The power supply must be installed in a well ventilated area and free from explosive gases and vapors. Proper operation requires the free flow of air. As this power supply is hardwired, it should be installed by a qualified electrician. UL class 2 recognized



REVO.6
04302024

2 / 2



7777 Merrimac Ave
Niles, IL 60714
T 224.333.6033
F 224.757.7557
info@luminii.com
www.luminii.com

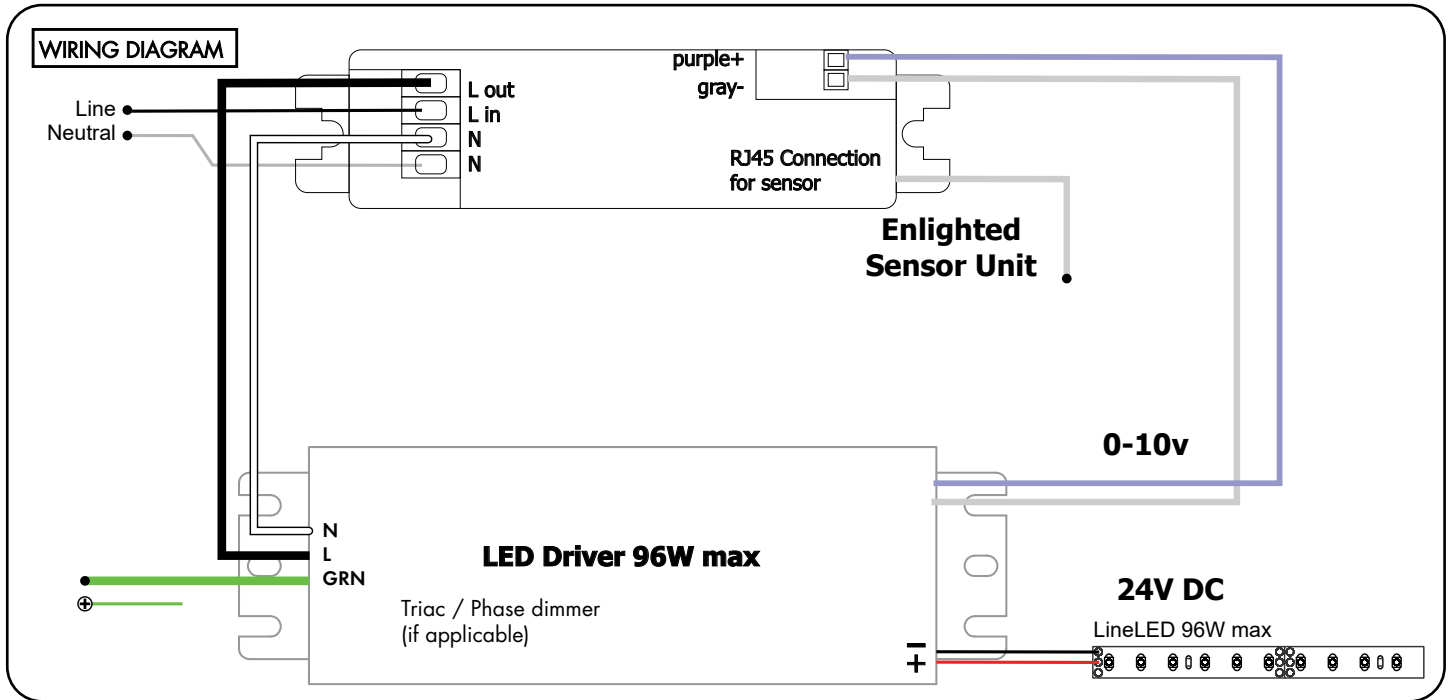

5

4.1 Insert the wire nut connections in the driver housing, close housing cover, and secure using the eight screws.

