

Features

- 24VDC Class 2 fixtures made to order up to 144". Fixtures can be linked up to 40' depending on output
- Suitable for undercabinet, surface mount, and direct view applications
- Approved for closet/storage space installation per NEC 410.16(A) (3) and 410.16(C)(5) on outputs 5.7W/ft or less
- Class 2 listed for damp locations
- Dot free even illumination with frosted lens
- High Color Quality options offer premium quality and vibrant colors with R9 values up to 97
- High Efficacy options offer best in class output and efficacy with over 760 lm/ft and up to 90 lm/W
- Proprietary strong bond solder method handles up to 50 lbs of pull force on wire leads and connectors
- 7 Year warranty

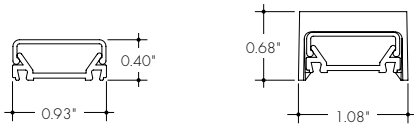

Finish Options

- White
- Black

(see page 2 for additional information)



Technical Information

| MODEL | High Color Quality | | | High Efficacy | |
|---|--------------------|-----------|-----------|---------------|-----------|
| OUTPUT OPTIONS | 72SO | 72HO | 72VHO | HE64VHO | HE64XHO |
| Lumens Output (3000K) <small>(with a Batwing Lens)</small> | 175 lm/ft | 284 lm/ft | 344 lm/ft | 679 lm/ft | 762 lm/ft |
| Average Power Consumption <small>(for a 4" section)</small> | 2.8 W/ft | 4.8 W/ft | 6.0 W/ft | 7.5 W/ft | 9.6 W/ft |
| Efficacy | 62 lm/W | 59 lm/W | 57 lm/W | 90 lm/W | 79 lm/W |
| Max Run Length <small>(in series)</small> | 40 ft | 31 ft | 22 ft | 15 ft | 13 ft |
| Operating Temperature* | 122°F | | | 113°F | 95°F |

*Max Ambient Temperature to maintain L70 of 50k+ hours in normal mounting conditions for the fixture. Exceeding Max Ambient Temperature may result in decreased life/output. Consult Technical Support for specific inquiries.

High Color Quality (72)

| CCT | Multiplier <small>(reference - 3000K)</small> | CRI | TM-30 | | |
|-------|--|-----|----------------|----------------|----------------|
| | | | R _f | R _g | R ₉ |
| 1900K | 0.55 | 96 | 94 | 97 | 90 |
| 2200K | 0.70 | 96 | 95 | 101 | 89 |
| 2400K | 0.72 | 98 | 97 | 101 | 91 |
| 2700K | 0.74 | 97 | 96 | 101 | 91 |
| 3000K | 1.00 | 97 | 95 | 104 | 97 |
| 3500K | 1.02 | 97 | 94 | 105 | 97 |
| 4100K | 1.07 | 97 | 90 | 99 | 97 |

High Efficacy (HE64)

| CCT | Multiplier <small>(reference - 3000K)</small> | CRI | TM-30 | | |
|-------|--|-----|----------------|----------------|----------------|
| | | | R _f | R _g | R ₉ |
| 2200K | 0.73 | 92 | 91 | 97 | 42 |
| 2500K | 0.81 | 93 | 96 | 96 | 62 |
| 2700K | 0.94 | 92 | 90 | 99 | 58 |
| 3000K | 1.00 | 92 | 89 | 99 | 57 |
| 3500K | 1.02 | 92 | 89 | 99 | 60 |
| 4000K | 1.02 | 92 | 86 | 94 | 71 |

Ordering Code

| MODEL | LENGTH ¹ | OUTPUT | CCT | LENS ² | MOUNTING | FINISH | POSITION TYPE | POWER FEED | ACCESSORIES ³ |
|-----------|-----------------------------|---|---|---|---|-----------------------------------|---|--|--|
| Bar- Bara | 12" - 144" 1" increments | 72SO-Standard 72HO-High 72VHO-Very High | 19K-1900K 22K-2200K 24K-2400K 27K-2700K 30K-3000K 35K-3500K 41K-4100K | F-Frosted N-Narrow Beam M-Medium BW-Batwing AS-Asymmetric | TB9-9/16" Lay-in Grid TB15-15/16" Lay-in Grid TT9-9/16" Tegular Clip TS9-9/16" Slot Tee Clip | WH-White BK-Black ⁴ | B-Back LB-Left Back* RB-Right Back* | 1-72" wire leads 1X2-72" wire leads at both ends 2-72" wire leads at one end and Quick Connect at other 3-Single Quick Connect 4-Dual Quick Connect P1-Plenum rated (72" wire leads) PIX2-Plenum rated (72" wire leads at both ends) | N/A, leave blank BLBK-Blade Louver, Black BLWB-Blade Louver, White/Black GSBK-Glare Shield, Black GSWB-Glare Shield, White/Black |
| | 12" - 144" 2" increments | HE64VHO-Very High HE64XHO-Max | 22K-2200K 25K-2500K 27K-2700K 30K-3000K 35K-3500K 40K-4000K | | | | | | |

1 - Custom lengths and increments are available, please consult Inside Sales with specific request.
2 - All High Efficacy options can be used to comply with Title 24 JAB. High Color Quality options can be used to comply with Title 24 JAB depending on Output, CCT, and Lens selections. See multiplier charts to calculate specific efficacies.

3 - Louver Accessories are not compatible with Asymmetric lens.

Product Dimensions

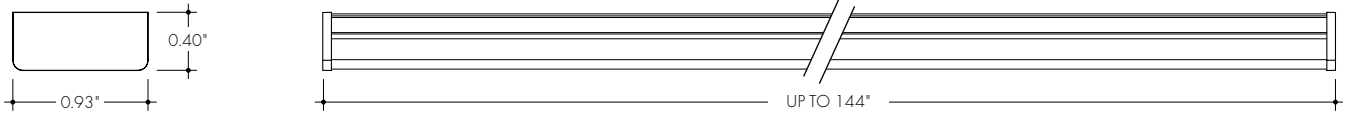

Mounting Clip Details

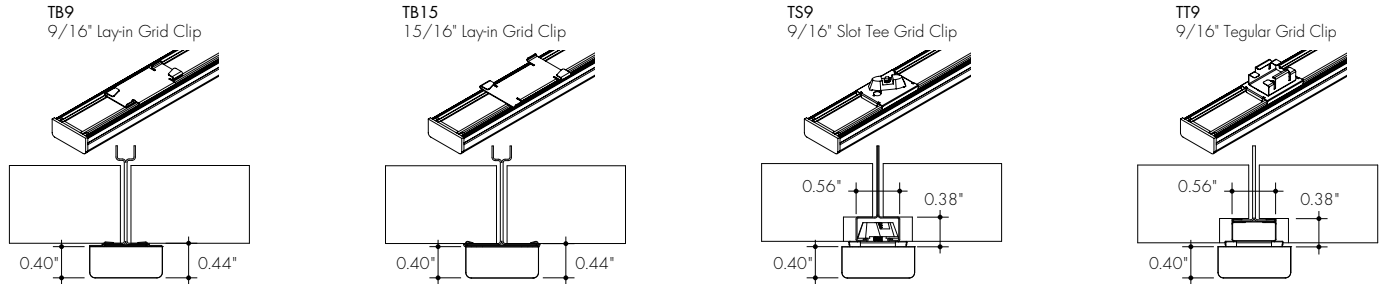

Lens Options

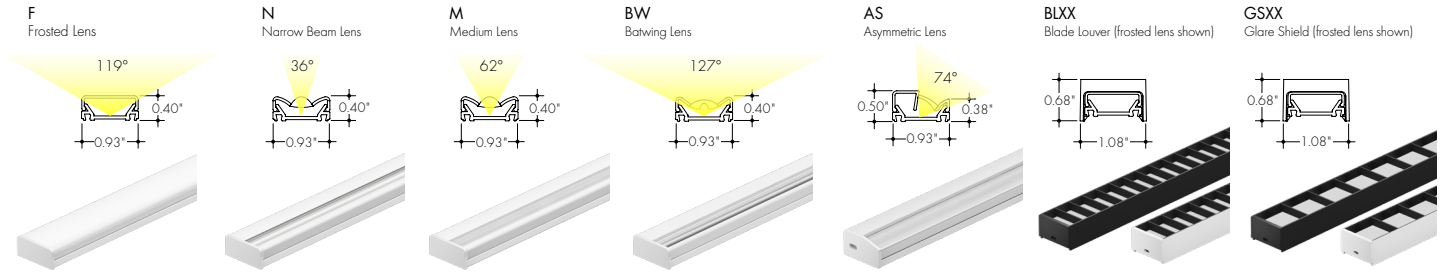

Black finish is only applicable when the black louver accessory is selected, for all other options, use the white finish.

| XX | Color |
|----|--------------------------------|
| BK | All Black |
| WB | White Exterior, Black Interior |

Finish Options

White
Powdered Coat

Black
Powdered Coat

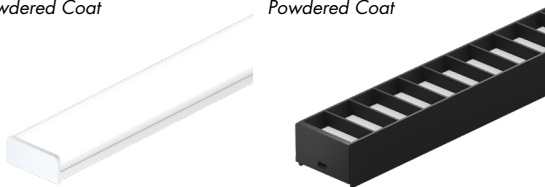

White is a polar bright white and field paintable.

Black is a true deep black with a glossy finish.

Powerfeeds and Connectors

Power Feed Position Options and Orientation

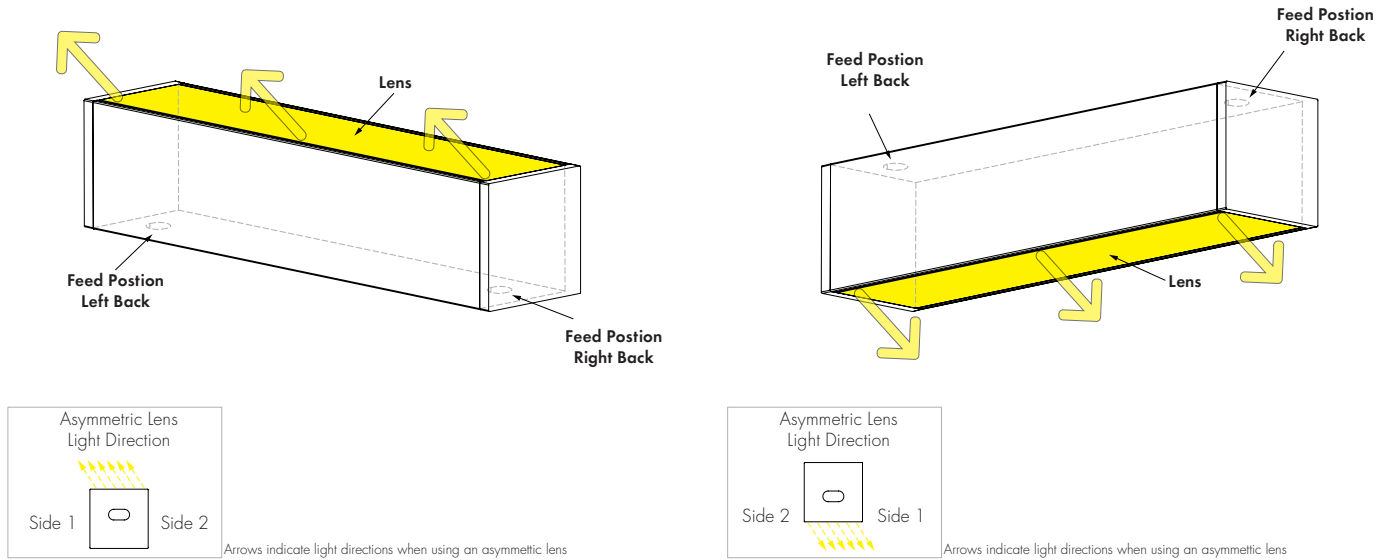

Powerfeeds and Connectors

Linking and Extension Cable Options

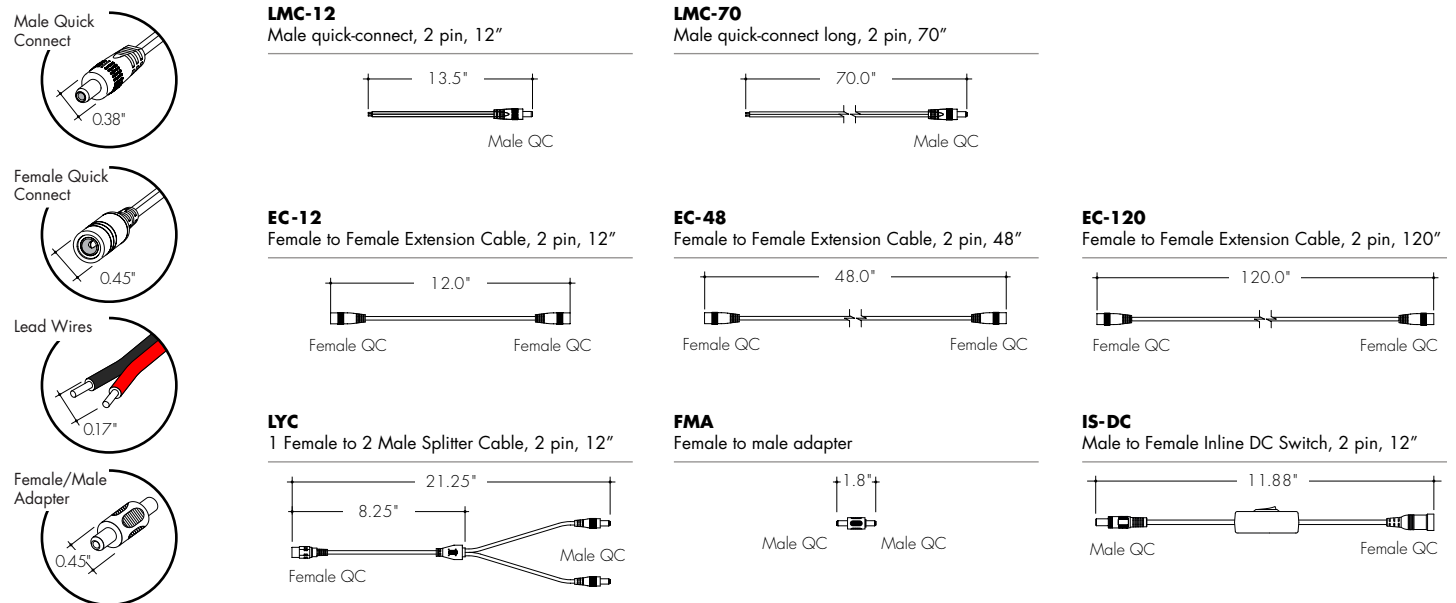

Sample Layout

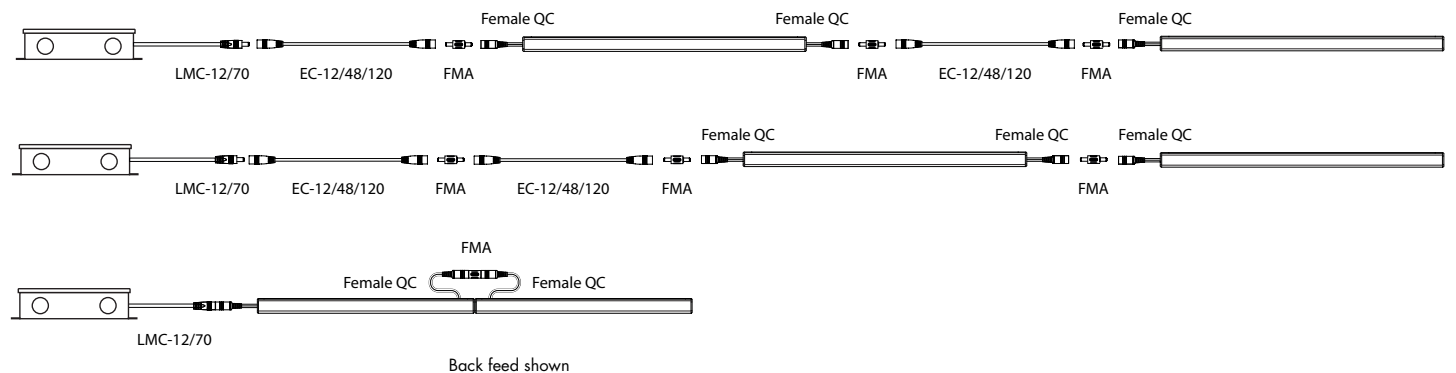

Light Transmission and Dotting

Lens/Accessory

| Output Options | Batwing Lens | Narrow Beam Lens | Frosted Lens | Medium Lens | Asymmetric Lens |
|---|--------------|------------------|--------------|-------------|-----------------|
| 72SO | CD | CD | ND | CD | CD |
| 72HO | CD | CD | ND | CD | CD |
| 72VHO | CD | CD | ND | CD | CD |
| HE64VHO | CD | CD | ND | CD | CD |
| HE64XHO | CD | CD | ND | CD | CD |
| Transmission Percentage | 100% | 97% | 91% | 88% | 76% |
| Transmission Percentage With Blade Louver | 42% | 48% | 35% | 42% | Not Compatible |
| Transmission Percentage With Glare Shield | 58% | 66% | 49% | 60% | Not Compatible |

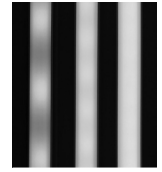

CD - Clear Dotting
SD - Slight Dotting
ND - No Dotting

Accessory Options

LV-BL-BARC-24-XX

Blade Louver reduces glare at high angle in two directions. Also available with complete fixture, use ordering code **-BLXX**

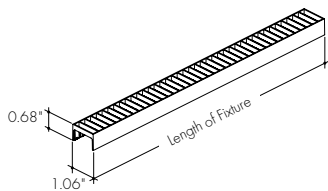

LV-GS-BARC-24-XX

Glare Shield reduces glare at high angle, field cuttable. Also available with complete fixture, use ordering code **-GSXX**

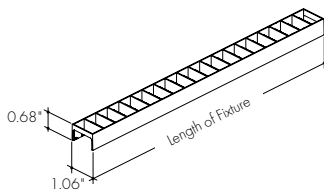

| XX | Color |
|----|--------------------------------|
| BK | All Black |
| WB | White Exterior, Black Interior |

LVSP-4T-BK

Low Voltage, 4 Terminal Splice Box, Black

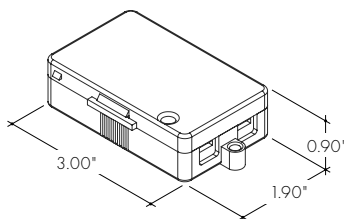

OS-DC-F4-BK

Occupancy Sensor

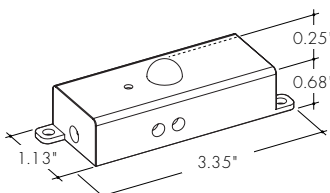

Male Quick Connect, FMA, IMC, LYC, or IS-DC are required for input and output.

DIM-DC-F4-BK

24VDC Low Voltage In-line Dimmer Module

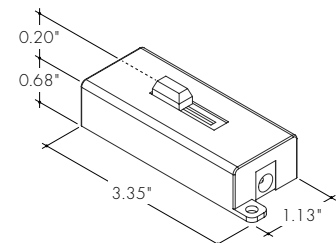

Male Quick Connect, FMA, IMC, LYC, or IS-DC are required for input and output.

Photometry

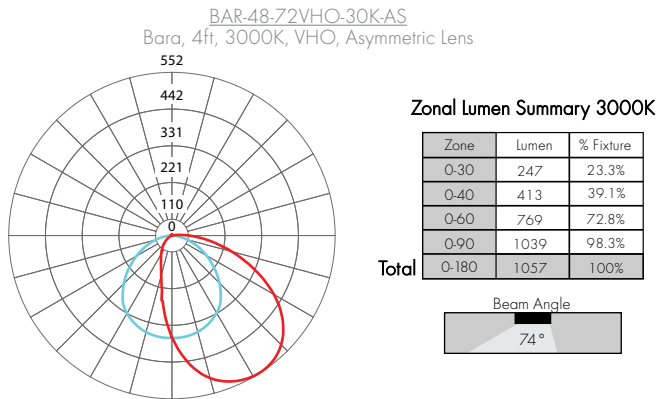
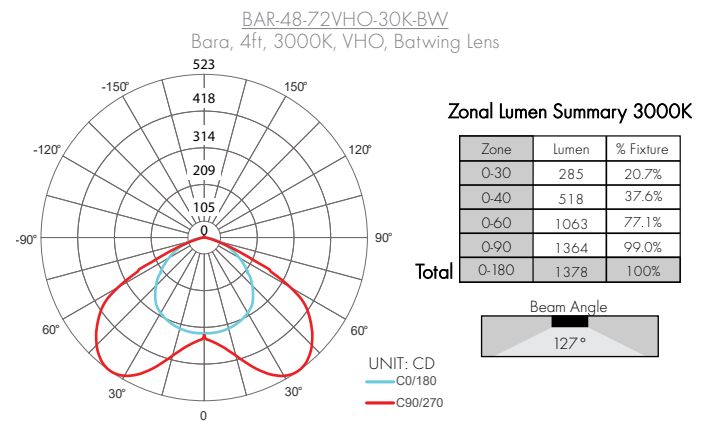
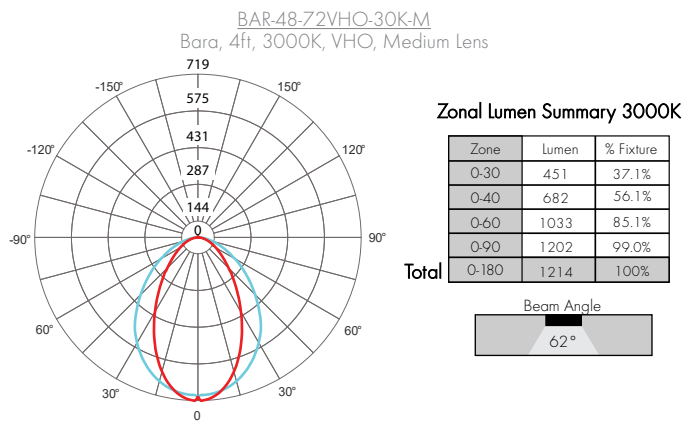
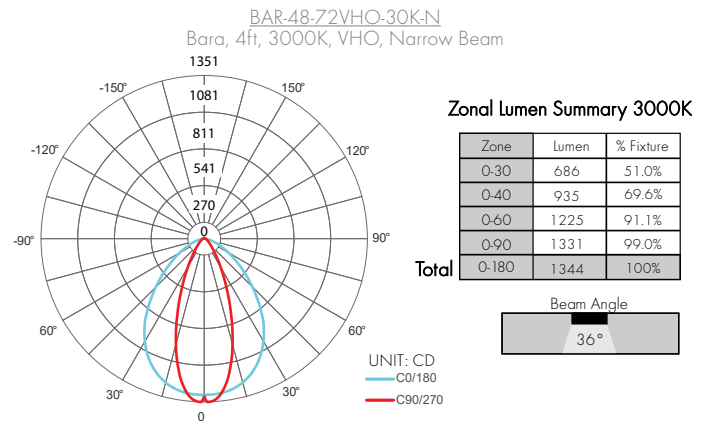
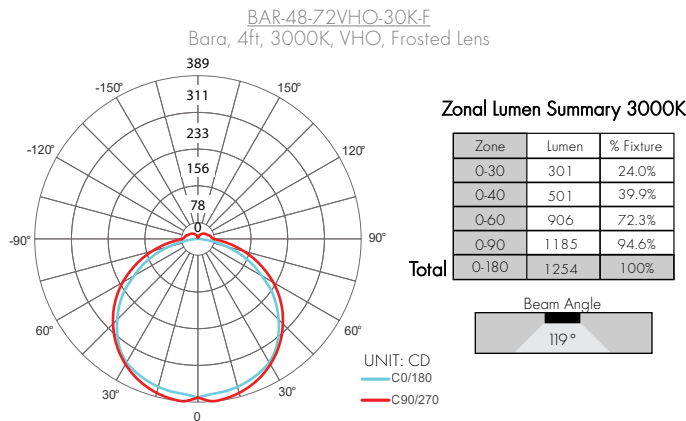

Photometry Charts

| | OUTPUT OPTIONS | LIGHT LOSS FACTOR |
|--------------------|---------------------------|-------------------|
| High Color Quality | 7250 | 51% |
| | 72HO | 82% |
| | 72VHO (Tested data shown) | 100% |
| High Efficacy | HE64VHO | 197% |
| | HE64XHO | 221% |

Power Consumption

Tested at Full Power with PDC Series power supplies.

*For Back Feed add 4/16" (1/4") to Actual Length. Standard Nominal Lengths offered provide minimal shadowing. For alternate lengths, please consult Inside Sales with specific request.

High Color Quality (72)

| Nominal Length (in) | End Feed Actual Length* | Watts | | | Nominal Length (in) | End Feed Actual Length* | Watts | | | Nominal Length (in) | End Feed Actual Length* | Watts | | | Nominal Length (in) | End Feed Actual Length* | Watts | | |
|---------------------|-------------------------|-------|------|------|---------------------|-------------------------|-------|------|------|---------------------|-------------------------|-------|------|------|---------------------|-------------------------|-------|------|------|
| | | SO | HO | VHO | | | SO | HO | VHO | | | SO | HO | VHO | | | SO | HO | VHO |
| 12 | 11 1/16 | 2.7 | 4.4 | 6.2 | 47 | 46 15/16 | 10.5 | 17.4 | 23.1 | 82 | 81 11/16 | 18.3 | 29.5 | 38.4 | 117 | 116 7/16 | 25.9 | 40.8 | 52.4 |
| 13 | 12 4/16 | 2.7 | 4.4 | 6.2 | 48 | - | - | - | - | 83 | 82 14/16 | 18.5 | 29.8 | 38.8 | 118 | 117 9/16 | 26.1 | 41.1 | 52.8 |
| 14 | 13 6/16 | 2.9 | 4.8 | 6.7 | 49 | 48 2/16 | 10.7 | 17.8 | 23.5 | 84 | - | - | - | - | 119 | 118 12/16 | 26.3 | 41.4 | 53.2 |
| 15 | 14 9/16 | 3.1 | 5.2 | 7.3 | 50 | 49 4/16 | 11.1 | 18.6 | 24.4 | 85 | 84 | 18.7 | 30.1 | 39.2 | 120 | 119 15/16 | 26.5 | 41.7 | 53.6 |
| 16 | 15 11/16 | 3.4 | 5.6 | 7.8 | 51 | 50 7/16 | 11.4 | 18.9 | 24.9 | 86 | 85 3/16 | 19.2 | 30.8 | 40.0 | 121 | - | - | - | - |
| 17 | 16 14/16 | 3.6 | 6.0 | 8.3 | 52 | 51 9/16 | 11.6 | 19.3 | 25.3 | 87 | 86 5/16 | 19.4 | 31.1 | 40.4 | 122 | 121 1/16 | 26.7 | 42.0 | 54.0 |
| 18 | - | - | - | - | 53 | 52 12/16 | 11.9 | 19.7 | 25.7 | 88 | 87 8/16 | 19.6 | 31.5 | 40.8 | 123 | 122 4/16 | 27.1 | 42.6 | 54.7 |
| 19 | 18 | 3.9 | 6.5 | 8.9 | 54 | 53 14/16 | 12.1 | 20.1 | 26.1 | 89 | 88 10/16 | 19.9 | 31.8 | 41.1 | 124 | 123 6/16 | 27.3 | 42.9 | 55.0 |
| 20 | 19 3/16 | 4.4 | 7.3 | 9.9 | 55 | - | - | - | - | 90 | 89 13/16 | 20.1 | 32.2 | 41.5 | 125 | 124 9/16 | 27.5 | 43.1 | 55.4 |
| 21 | 20 5/16 | 4.6 | 7.7 | 10.5 | 56 | 55 1/16 | 12.3 | 20.5 | 26.6 | 91 | 90 15/16 | 20.4 | 32.5 | 41.9 | 126 | 125 11/16 | 27.7 | 43.4 | 55.7 |
| 22 | 21 8/16 | 4.8 | 8.1 | 11.0 | 57 | 56 4/16 | 12.8 | 21.3 | 27.4 | 92 | - | - | - | - | 127 | 126 14/16 | 27.9 | 43.7 | 56.1 |
| 23 | 22 10/16 | 5.1 | 8.6 | 11.5 | 58 | 57 6/16 | 13.1 | 21.6 | 27.8 | 93 | 92 2/16 | 20.6 | 32.9 | 42.3 | 128 | - | - | - | - |
| 24 | 23 13/16 | 5.3 | 9.0 | 12.1 | 59 | 58 9/16 | 13.3 | 22.0 | 28.3 | 94 | 93 4/16 | 21.1 | 33.6 | 43.1 | 129 | 128 | 28.1 | 43.9 | 56.4 |
| 25 | 24 15/16 | 5.6 | 9.4 | 12.6 | 60 | 59 11/16 | 13.6 | 22.4 | 28.7 | 95 | 94 7/16 | 21.3 | 33.9 | 43.4 | 130 | 129 3/16 | 28.5 | 44.5 | 57.1 |
| 26 | - | - | - | - | 61 | 60 14/16 | 13.8 | 22.8 | 29.1 | 96 | 95 9/16 | 21.5 | 34.2 | 43.8 | 131 | 130 5/16 | 28.7 | 44.7 | 57.4 |
| 27 | 26 2/16 | 5.8 | 9.8 | 13.1 | 62 | - | - | - | - | 97 | 96 12/16 | 21.8 | 34.6 | 44.2 | 132 | 131 8/16 | 28.9 | 45.0 | 57.8 |
| 28 | 27 4/16 | 6.2 | 10.5 | 14.1 | 63 | 62 | 14.0 | 23.1 | 29.6 | 98 | 97 15/16 | 22.0 | 34.9 | 44.6 | 133 | 132 10/16 | 29.1 | 45.3 | 58.1 |
| 29 | 28 7/16 | 6.5 | 10.9 | 14.5 | 64 | 63 3/16 | 14.5 | 23.8 | 30.5 | 99 | - | - | - | - | 134 | 133 13/16 | 29.3 | 45.5 | 58.4 |
| 30 | 29 9/16 | 6.7 | 11.2 | 15.0 | 65 | 64 5/16 | 14.7 | 24.1 | 31.0 | 100 | 99 1/16 | 22.2 | 35.2 | 45.0 | 135 | 134 15/16 | 29.5 | 45.7 | 58.7 |
| 31 | 30 12/16 | 6.9 | 11.6 | 15.5 | 66 | 65 8/16 | 14.9 | 24.4 | 31.4 | 101 | 100 4/16 | 22.5 | 35.9 | 45.9 | 136 | - | - | - | - |
| 32 | 31 14/16 | 7.1 | 12.0 | 16.0 | 67 | 66 10/16 | 15.1 | 24.7 | 31.9 | 102 | 101 6/16 | 22.7 | 36.2 | 46.3 | 137 | 136 2/16 | 29.6 | 45.9 | 59.1 |
| 33 | - | - | - | - | 68 | 67 13/16 | 15.3 | 25.0 | 32.4 | 103 | 102 9/16 | 22.9 | 36.5 | 46.7 | 138 | 137 4/16 | 30.0 | 46.3 | 59.7 |
| 34 | 33 1/16 | 7.3 | 12.3 | 16.5 | 69 | 68 15/16 | 15.5 | 25.4 | 32.8 | 104 | 103 11/16 | 23.1 | 36.8 | 47.1 | 139 | 138 7/16 | 30.2 | 46.5 | 60.0 |
| 35 | 34 4/16 | 7.8 | 13.1 | 17.4 | 70 | - | - | - | - | 105 | 104 14/16 | 23.3 | 37.1 | 47.5 | 140 | 139 9/16 | 30.3 | 46.8 | 60.3 |
| 36 | 35 6/16 | 8.0 | 13.4 | 17.9 | 71 | 70 2/16 | 15.8 | 25.7 | 33.3 | 106 | - | - | - | - | 141 | 140 12/16 | 30.5 | 47.0 | 60.6 |
| 37 | 36 9/16 | 8.2 | 13.8 | 18.4 | 72 | 71 4/16 | 16.2 | 26.3 | 34.2 | 107 | 106 | 23.5 | 37.4 | 48.0 | 142 | 141 15/16 | 30.7 | 47.2 | 61.0 |
| 38 | 37 11/16 | 8.4 | 14.2 | 18.9 | 73 | 72 7/16 | 16.4 | 26.6 | 34.7 | 108 | 107 3/16 | 23.9 | 38.1 | 48.8 | 143 | - | - | - | - |
| 39 | 38 14/16 | 8.7 | 14.5 | 19.3 | 74 | 73 9/16 | 16.6 | 26.9 | 35.1 | 109 | 108 5/16 | 24.1 | 38.4 | 49.2 | 144 | 143 1/16 | 30.8 | 47.4 | 61.3 |
| 40 | - | - | - | - | 75 | 74 12/16 | 16.8 | 27.3 | 35.5 | 110 | 109 8/16 | 24.3 | 38.7 | 49.6 | | | | | |
| 41 | 40 | 8.9 | 14.9 | 19.8 | 76 | 75 14/16 | 17.1 | 27.6 | 35.9 | 111 | 110 10/16 | 24.5 | 39.0 | 50.0 | | | | | |
| 42 | 41 3/16 | 9.3 | 15.6 | 20.7 | 77 | - | - | - | - | 112 | 111 13/16 | 24.8 | 39.3 | 50.4 | | | | | |
| 43 | 42 5/16 | 9.6 | 16.0 | 21.2 | 78 | 77 1/16 | 17.3 | 27.9 | 36.3 | 113 | 112 15/16 | 25.0 | 39.6 | 50.8 | | | | | |
| 44 | 43 8/16 | 9.8 | 16.4 | 21.7 | 79 | 78 4/16 | 17.7 | 28.5 | 37.2 | 114 | - | - | - | - | | | | | |
| 45 | 44 10/16 | 10.0 | 16.7 | 22.1 | 80 | 79 6/16 | 17.9 | 28.9 | 37.6 | 115 | 114 2/16 | 25.2 | 39.9 | 51.2 | | | | | |
| 46 | 45 13/16 | 10.2 | 17.1 | 22.6 | 81 | 80 9/16 | 18.1 | 29.2 | 38.0 | 116 | 115 4/16 | 25.6 | 40.5 | 52.0 | | | | | |

Power Consumption

Tested at Full Power with PDC Series power supplies.

*For Back Feed add 4/16" (1/4") to Actual Length. Standard Nominal Lengths offered provide minimal shadowing. For alternate lengths, please consult Inside Sales with specific request.

High Efficacy (HE64)

| Nominal Length (in) | End Feed Actual Length* | Watts | | Nominal Length (in) | End Feed Actual Length* | Watts | | Nominal Length (in) | End Feed Actual Length* | Watts | | Nominal Length (in) | End Feed Actual Length* | Watts | |
|---------------------|-------------------------|-------|------|---------------------|-------------------------|-------|------|---------------------|-------------------------|-------|------|---------------------|-------------------------|-------|------|
| | | VHO | XHO | | | VHO | XHO | | | VHO | XHO | | | VHO | XHO |
| 12 | 11 4/16 | 7.6 | 9.7 | 47 | 46 1/16 | 28.2 | 35.9 | 82 | - | - | - | 117 | - | - | - |
| 13 | 12 12/16 | 7.6 | 9.7 | 48 | 47 9/16 | 29.5 | 37.6 | 83 | 82 7/16 | 51.7 | 63.4 | 118 | 117 4/16 | 72.8 | 80.7 |
| 14 | - | - | - | 49 | - | - | - | 84 | 83 15/16 | 52.3 | 63.8 | 119 | 118 12/16 | 73.3 | 81.0 |
| 15 | 14 4/16 | 8.9 | 11.3 | 50 | 49 2/16 | 30.1 | 38.4 | 85 | - | - | - | 120 | - | - | - |
| 16 | 15 13/16 | 9.5 | 12.1 | 51 | 50 10/16 | 31.4 | 40.2 | 86 | 85 7/16 | 53.6 | 64.7 | 121 | 120 4/16 | 74.4 | 81.7 |
| 17 | - | - | - | 52 | - | - | - | 87 | 86 15/16 | 54.2 | 65.3 | 122 | 121 12/16 | 74.8 | 82.0 |
| 18 | 17 5/16 | 10.7 | 13.6 | 53 | 52 2/16 | 32.0 | 41.1 | 88 | - | - | - | 123 | - | - | - |
| 19 | 18 13/16 | 11.4 | 14.4 | 54 | 53 10/16 | 33.3 | 42.9 | 89 | 88 7/16 | 55.5 | 66.3 | 124 | 123 5/16 | 75.6 | 82.5 |
| 20 | - | - | - | 55 | - | - | - | 90 | 90 | 56.2 | 66.8 | 125 | 124 13/16 | 76.0 | 82.8 |
| 21 | 20 5/16 | 12.6 | 16.0 | 56 | 55 2/16 | 34.0 | 43.8 | 91 | - | - | - | 126 | - | - | - |
| 22 | 21 13/16 | 13.2 | 16.8 | 57 | 56 11/16 | 35.2 | 45.5 | 92 | 91 8/16 | 57.5 | 67.9 | 127 | 126 5/16 | 76.8 | 83.4 |
| 23 | - | - | - | 58 | - | - | - | 93 | - | - | - | 128 | 127 13/16 | 77.2 | 83.6 |
| 24 | 23 6/16 | 14.5 | 18.3 | 59 | 58 3/16 | 36.5 | 47.3 | 94 | 93 | 58.2 | 68.4 | 129 | - | - | - |
| 25 | 24 14/16 | 15.1 | 19.1 | 60 | 59 11/16 | 37.2 | 48.2 | 95 | 94 8/16 | 59.5 | 69.5 | 130 | 129 6/16 | 78.0 | 84.2 |
| 26 | - | - | - | 61 | - | - | - | 96 | - | - | - | 131 | 130 14/16 | 78.4 | 84.5 |
| 27 | 26 6/16 | 16.4 | 20.7 | 62 | 61 3/16 | 38.4 | 50.0 | 97 | 96 1/16 | 60.1 | 70.0 | 132 | - | - | - |
| 28 | 27 14/16 | 17.0 | 21.4 | 63 | 62 12/16 | 39.1 | 50.8 | 98 | 97 9/16 | 61.4 | 71.1 | 133 | 132 6/16 | 79.2 | 85.0 |
| 29 | - | - | - | 64 | - | - | - | 99 | - | - | - | 134 | 133 14/16 | 79.6 | 85.4 |
| 30 | 29 7/16 | 18.2 | 23.0 | 65 | 64 4/16 | 40.4 | 52.5 | 100 | 99 1/16 | 62.0 | 71.7 | 135 | - | - | - |
| 31 | 30 15/16 | 18.9 | 23.8 | 66 | 65 12/16 | 41.0 | 53.4 | 101 | 100 9/16 | 63.2 | 72.9 | 136 | 135 7/16 | 80.3 | 86.2 |
| 32 | - | - | - | 67 | - | - | - | 102 | - | - | - | 137 | 136 15/16 | 80.6 | 86.6 |
| 33 | 32 7/16 | 20.1 | 25.3 | 68 | 67 4/16 | 42.3 | 55.1 | 103 | 102 1/16 | 63.8 | 73.5 | 138 | - | - | - |
| 34 | 33 15/16 | 20.7 | 26.1 | 69 | 68 12/16 | 42.9 | 55.9 | 104 | 103 10/16 | 65.0 | 74.7 | 139 | 138 7/16 | 81.3 | 87.5 |
| 35 | - | - | - | 70 | - | - | - | 105 | - | - | - | 140 | 139 15/16 | 81.7 | 87.9 |
| 36 | 35 7/16 | 22.0 | 27.6 | 71 | 70 5/16 | 44.2 | 57.6 | 106 | 105 2/16 | 65.6 | 75.3 | 141 | - | - | - |
| 37 | 37 | 22.6 | 28.4 | 72 | 71 13/16 | 44.9 | 58.5 | 107 | 106 10/16 | 66.8 | 76.5 | 142 | 141 7/16 | 82.4 | 88.7 |
| 38 | - | - | - | 73 | - | - | - | 108 | - | - | - | 143 | 143 | 82.7 | 89.1 |
| 39 | 38 8/16 | 23.9 | 30.1 | 74 | 73 5/16 | 46.1 | 59.7 | 109 | 108 2/16 | 67.4 | 77.1 | 144 | - | - | - |
| 40 | - | - | - | 75 | 74 13/16 | 46.7 | 60.1 | 110 | 109 11/16 | 68.5 | 78.0 | | | | |
| 41 | 40 | 24.5 | 30.9 | 76 | - | - | - | 111 | - | - | - | | | | |
| 42 | 41 8/16 | 25.7 | 32.6 | 77 | 76 6/16 | 48.0 | 60.9 | 112 | 111 3/16 | 69.6 | 78.7 | | | | |
| 43 | - | - | - | 78 | 77 14/16 | 48.6 | 61.3 | 113 | 112 11/16 | 70.1 | 79.0 | | | | |
| 44 | 43 1/16 | 26.4 | 33.4 | 79 | - | - | - | 114 | - | - | - | | | | |
| 45 | 44 9/16 | 27.6 | 35.1 | 80 | 79 6/16 | 49.8 | 62.2 | 115 | 114 3/16 | 71.2 | 79.7 | | | | |
| 46 | - | - | - | 81 | 80 14/16 | 50.4 | 62.6 | 116 | 115 12/16 | 71.7 | 80.0 | | | | |

Voltage Drop Calculator

The below chart assumes nominal voltage of 24 Volts and a Voltage Drop Allowance of 3% through the wire

| Wattage [W] | Maximum Wire Length From Power Supply to Start of Run [ft] | | | | | | |
|-------------|--|--------|--------|--------|--------|--------|--------|
| | 12 AWG | 14 AWG | 16 AWG | 18 AWG | 20 AWG | 22 AWG | 24 AWG |
| 5 | 1088.2 | 684.4 | 430.3 | 270.6 | 170.2 | 107.1 | 67.3 |
| 10 | 544.1 | 342.2 | 215.1 | 135.3 | 85.1 | 53.5 | 33.7 |
| 15 | 362.7 | 228.1 | 143.4 | 90.2 | 56.7 | 35.7 | 22.4 |
| 20 | 272.0 | 171.1 | 107.6 | 67.7 | 42.6 | 26.8 | 16.8 |
| 25 | 217.6 | 136.9 | 86.1 | 54.1 | 34.0 | 21.4 | 13.5 |
| 30 | 181.4 | 114.1 | 71.7 | 45.1 | 28.4 | 17.8 | 11.2 |
| 35 | 155.5 | 97.8 | 61.5 | 38.7 | 24.3 | 15.3 | 9.6 |
| 40 | 136.0 | 85.5 | 53.8 | 33.8 | 21.3 | 13.4 | 8.4 |
| 45 | 120.9 | 76.0 | 47.8 | 30.1 | 18.9 | 11.9 | 7.5 |
| 50 | 108.8 | 68.4 | 43.0 | 27.1 | 17.0 | 10.7 | 6.7 |
| 55 | 98.9 | 62.2 | 39.1 | 24.6 | 15.5 | 9.7 | 6.1 |
| 60 | 90.7 | 57.0 | 35.9 | 22.6 | 14.2 | 8.9 | 5.6 |
| 65 | 83.7 | 52.6 | 33.1 | 20.8 | 13.1 | 8.2 | 5.2 |
| 70 | 77.7 | 48.9 | 30.7 | 19.3 | 12.2 | 7.6 | 4.8 |
| 75 | 72.5 | 45.6 | 28.7 | 18.0 | 11.3 | 7.1 | 4.5 |
| 80 | 68.0 | 42.8 | 26.9 | 16.9 | 10.6 | 6.7 | 4.2 |
| 85 | 64.0 | 40.3 | 25.3 | 15.9 | 10.0 | 6.3 | 4.0 |
| 90 | 60.5 | 38.0 | 23.9 | 15.0 | 9.5 | 5.9 | 3.7 |
| 96 | 56.7 | 35.6 | 22.4 | 14.1 | 8.9 | 5.6 | 3.5 |

T-Grid Compatibility

| Luminii Mounting | Brand | Type | Part Number | Description |
|------------------|-------|-----------|-------------|--|
| TB15 | USG | 15/16 | AX26 | DONN AX SUSPENSION |
| TB15 | | 15/16 | DX24 | DX®/DXL™ ACOUSTICAL SUSPENSION SYSTEM |
| TB15 | | 15/16 | M7 | M7 OVERLAPPING |
| TS9 | | 9/16 | DXFF2930 | Donn® Brand Finline® 1/8 DXFF™ 9/16" ACOUSTICAL SUSPENSION SYSTEM |
| TS9 | | 9/16 | DXF2930 | Donn® Brand Finline® DXF™/DXLF™ 9/16" ACOUSTICAL SUSPENSION SYSTEM |
| TT9 | | 9/16 | DXT24 | Donn® Brand Centricitee™ DXT™/DXLT™ 9/16" ACOUSTICAL SUSPENSION SYSTEM |
| TB9 | | ARMSTRONG | 9/16 | 7501HRC |
| TB15 | 15/16 | | 7301HRC | PRELUDE XL HRC EXPOSED TEE SYSTEM |
| TB15 | 15/16 | | 7301 | PRELUDE ML EXPOSED TEE SYSTEM |
| TB15 | 15/16 | | 8301 | PRELUDE XL FIRE EXPOSED TEE SYSTEM |
| TS9 | 9/16 | | 76018 | SILHOUETTE XL 9/16" BOLT SLOT - 1/8" |
| TS9 | 9/16 | | 7601 | SILHOUETTE XL 9/16" BOLT SLOT - 1/4" |
| TT9 | 9/16 | | 7501 | SUPRAFINE XL 9/16" EXPOSED TEE |
| TT9 | 9/16 | | ML7540 | SUPRAFINE ML 9/16" EXPOSED TEE |

*** Statement of Compatibility from USG:**

Luminii's fixtures at 0.25lbs/ft can be fully supported by the USG grids listed in the table above and do not require any additional structural support or modifications to the grid system as long as the overall ceiling weight including specified fixtures and/or any other components supported by the grid does not cross the allowed ceiling weight per state building structural codes.

Power Supplies

See Power Supply instructions and spec sheet for wiring information. For a complete list of compatible dimmers, see Compatible Dimming Chart on the Resources page.

Universal Power Supply 1% 120VAC - 277VAC

| MODEL | POWER | OUTPUT |
|--------------------------|--|-------------|
| PDCU-D - IP20 Dry Series | 30 - 30 W 60 - 60 W 96 - 96 W 3X96 - 3X96 W | 24 - 24 VDC |
| PDCU-W - IP66 Wet Series | 96 - 96 W 3X96 - 3X96 W | |

0-10V dims down to 1%, MLV/ELV/TRIAC dims down to 1%.
For a complete list of compatible dimmers, see [Compatible Dimming Chart](#) on the Resources page.

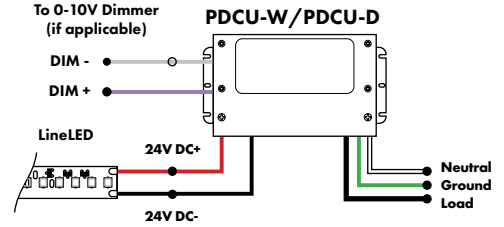

| MODELS | PDCU-W 96W | PDCU-W 3X96W | PDCU-D 30W | PDCU-D 60W | PDCU-D 96W | PDCU-D 3X96W |
|---------------|------------|--------------|------------|------------|------------|--------------|
| Length | 8.66" | 11.85" | 6.10" | 7.93" | 8.25" | 9.57" |
| Width | 3.73" | 4.32" | 3.35" | 3.35" | 4.10" | 5.94" |
| Depth | 1.61" | 1.81" | 1.33" | 1.32" | 1.56" | 1.13" |

0-10V Dimming Power Supplies 0.1% 120VAC - 277VAC

| MODEL | POWER | OUTPUT | DIMMING |
|--|------------------------------------|-------------|-----------------------------------|
| PS010V - 0-10V Power Supply dims down to 0.1% | 96 - 96 Watt 3X96 - 3 X 96 Watt | 24 - 24 VDC | LIN - Linear LOG - Logarithmic |

| MODELS | 96W | 3X96 |
|---------------|--------|--------|
| Length | 14.40" | 15.75" |
| Width | 5.20" | 6.62" |
| Depth | 2.60" | 4.95" |

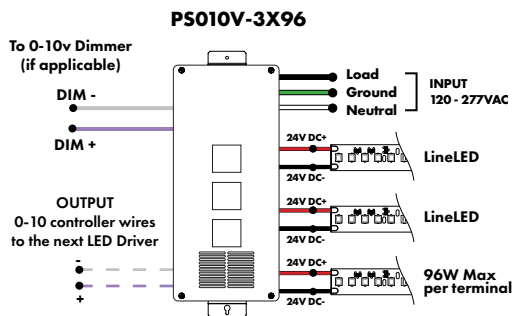
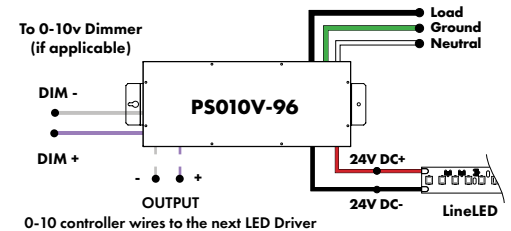

Triac, MLV, & ELV Compatible Dimmers

| MODEL | POWER | OUTPUT |
|---------------------------|---------------|-------------|
| PDC - (IP20) Power Supply | 96 - 96 Watts | 24 - 24 VDC |

| MODELS | 96W |
|---------------|-------|
| Length | 8.25" |
| Width | 4.10" |
| Depth | 1.56" |

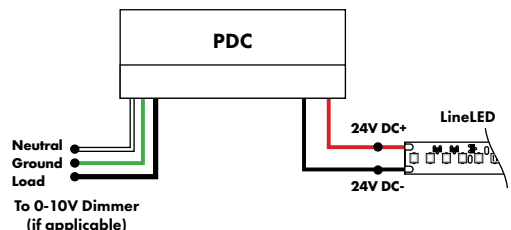

Power Supplies

See Power Supply instructions and spec sheet for wiring information. For a complete list of compatible dimmers, see Compatible Dimming Chart on the Resources page.

DMX Dimming Power Supplies 120VAC - 277VAC

| MODEL | POWER | OUTPUT |
|---|------------------------------------|-------------|
| PSDMX - DMX Power Supply dims down to 0% | 96 - 96 Watt 3X96 - 3 X 96 Watt | 24 - 24 VDC |

Features eldoLED's LINEARdrive configurable dimmable drivers

| MODELS | 96W | 3X96 |
|---------------|--------|--------|
| Length | 14.40" | 15.75" |
| Width | 5.20" | 6.62" |
| Depth | 2.60" | 4.95" |

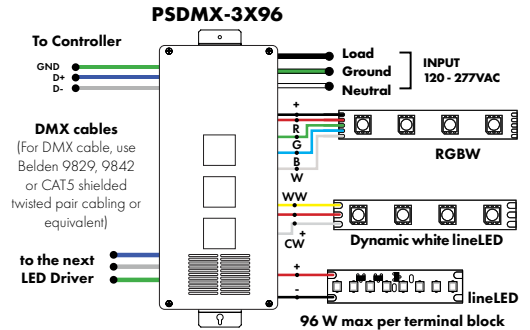
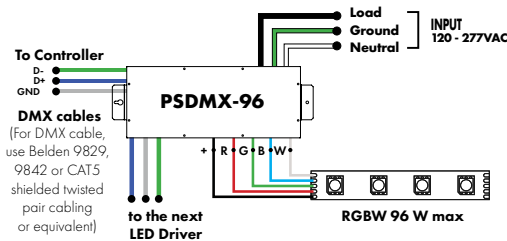

DALI 0% Dimming Power Supplies 120VAC - 277VAC

| MODEL | POWER | OUTPUT |
|---|------------------------------------|-------------|
| PSDALI - DALI Power Supply dims down to 0% | 96 - 96 Watt 3X96 - 3 X 96 Watt | 24 - 24 VDC |

Features eldoLED's LINEARdrive configurable dimmable drivers

| Model | 96W | 3X96 |
|---------------|--------|--------|
| Length | 14.40" | 15.75" |
| Width | 5.20" | 6.62" |
| Depth | 2.60" | 4.95" |

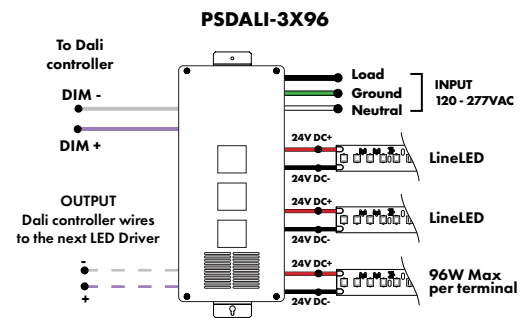
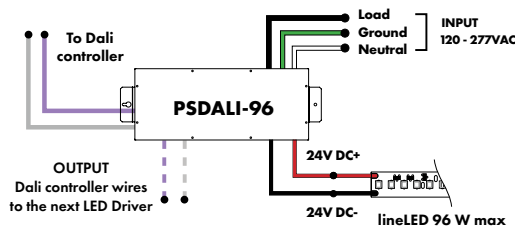

Enlighted Enabled Dimming Power Supplies 120VAC - 277VAC

| MODEL | POWER | OUTPUT | DIMMING | LOCATION |
|------------------|--------------|-------------|--|----------|
| PSV - PSV Series | 96 - 96 Watt | 24 - 24 VDC | ENL - Enlighted Dimming dims down to 0% | D - Damp |

| | |
|---------------|------------|
| Model | 96W |
| Length | 14.40" |
| Width | 5.20" |
| Depth | 2.60" |

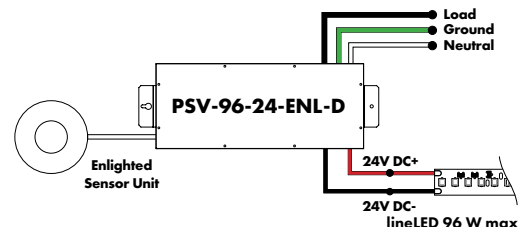

Power Supplies

See Power Supply instructions and spec sheet for wiring information. For a complete list of compatible dimmers, see Compatible Dimming Chart on the Resources page.

Non-Dimming Power Supply 120VAC - 277VAC

| MODEL | POWER | OUTPUT | DIMMING | LOCATION |
|------------------|--------------|-------------|------------------|----------|
| PSV - PSV Series | 96 - 96 Watt | 24 - 24 VDC | ND - Non Dimming | D - Damp |

| MODELS | 96W |
|--------|--------|
| Length | 14.40" |
| Width | 5.20" |
| Depth | 2.60" |

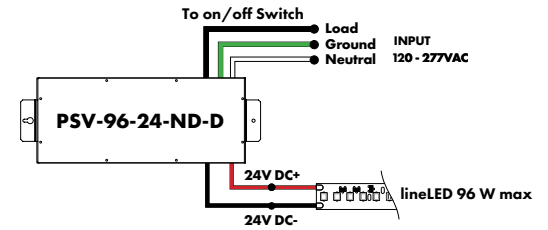

Luminii is a Lutron OEM Advantage Partner

Lutron Power Supplies 1%

| MODEL |
|------------------|
| L3DA4U1UKL-CV240 |

HiLume™ 1% EcoSystem Voltage LED driver
40W max

| MODELS | L3DA4U1UKL-CV240 |
|--------|------------------|
| Length | 4.98" |
| Width | 4.00" |
| Depth | 2.62" |

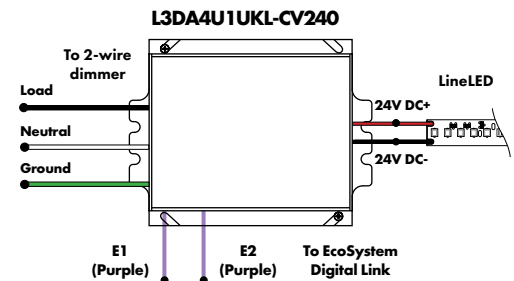

Luminii is a Lutron OEM Advantage Partner

Lutron Power Supplies 0.1%

| MODEL |
|---------------|
| L3D0-96W24V-U |

HiLume™ 0.1% EcoSystem Voltage LED Driver with Soft-On, Fade-to-Black™
96W max

| MODELS | L3D0 |
|--------|--------|
| Length | 10.50" |
| Width | 5.50" |
| Depth | 2.00" |

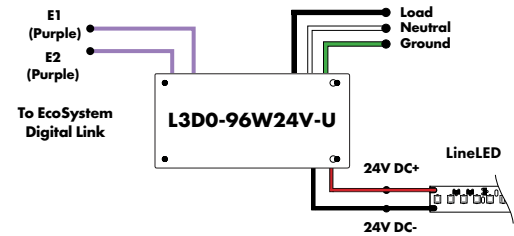

In-Ground Power Supplies

| MODEL | POWER | OUTPUT | INPUT |
|---|--------------------|-------------|----------------------------------|
| IG - In ground CVE Series CVE - ELV Dimming DALI - eldoLED Dali dimming Both dims down to 0% | 96X2 - 2 X 96 Watt | 24 - 24 VDC | Blank - 120 V 277 - 240/277 V |

| MODELS | Dual Circuit |
|--------|--------------|
| Length | 8.40" |
| Width | 8.30" |
| Depth | 8.10" |

