

NARROW

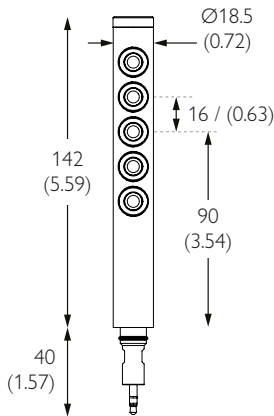
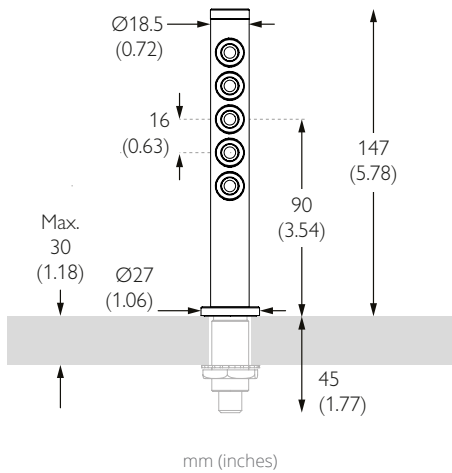

TECHNICAL DESCRIPTION

Stacko Straight Fixed End is a Constant Current miniature display lighting product. It has four beam distributions and is a part of the modular Stacko Collection allowing users to 'stack' products together to create unique lighting set-ups that comes as standard in white, black and brushed aluminium. There are 5 light engines totalling 510lm | 5.60W. Each narrow beam in our 102lm light engine has a peak intensity of 794cd. This 'End' module closes the circuit and does not accept further modules. There can only be a maximum of 10 light engines per Stacko circuit or driver. The luminaire is compatible with our Minipoint system that enables a plug and play setup where luminaires can be swapped to suit changing lighting requirements.

MECHANICAL & ELECTRICAL

CATEGORY IP20	WATTAGE 5.60W
MATERIAL Machined AL 6063-T6 Machined Brass	FORWARD VOLTAGE 16V
PAN 360°	DRIVE CURRENT 350mA
TILT N/A	SUPPLY TYPE Constant Current
LOCKABLE N/A	DRIVER LOCATION Remote
WEIGHT 79g 0.17lb	DIMMING DALI 0-10V 1-10V

MOUNTING

MOUNTING Minipoints	CUTOUT ø18mm (0.71") minipoint
CEILING THICKNESS 30mm (1.18") max	MIN CEILING VOID N/A

FINISHES

FINISHES Brushed Aluminium | White RAL9010 | Matte Black Anodised | Rubbed Bronze* | Polished Brass* | Brushed Brass* | Polished Nickel*
*Premium & custom finishes are built & finished to order. These are subject to an extended lead time & MOQ.

OPTICAL & STANDARDS

TOTAL NOMINAL LUMENS 510lm	BEAM ANGLE 16°
TOTAL DELIVERED LUMENS 470lm	CRI 95 TYP
LIGHT ENGINE DELIVERED LUMENS 94lm	TM-30 RF: 93 RG: 99
LIGHT ENGINES 5	WARRANTY 5 Years
COLOUR TEMPERATURE 2700K 3000K	STANDARDS
ACCESSORY HOLDER N/A	
ACCESSORIES N/A	

Photometry shown is for 3000K module. Please enquire for other CCT photometry. L90 50,000 hours.

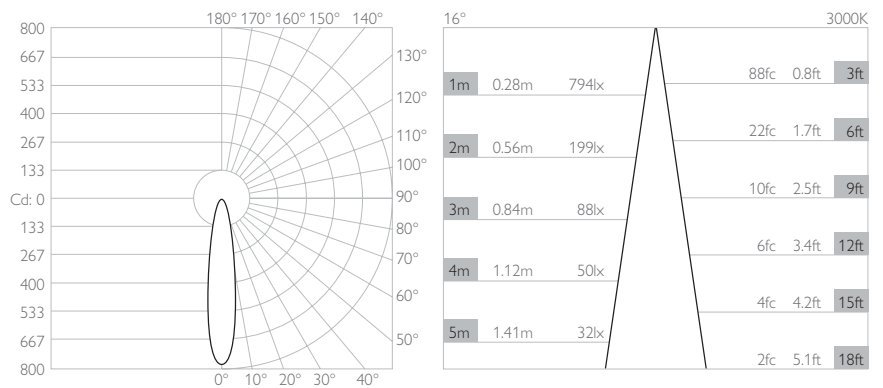

LUMINAIRE FINISH

	White 9010	Matt Anodised Black	Brushed Aluminium	Rubbed Bronze*	Polished Brass*	Brushed Brass*
Without Minipoint	1005-E-WH-XX9516	1005-E-EBA-XX9516	1005-E-AL-XX9516	1005-E-RB-XX9516	1005-E-PB-XX9516	1005-E-SB-XX9516
With Minipoint						

*All premium & custom finishes are built & finished to order. These are subject to an extended lead time & MOQ

For 3000K Substitute XX with 30

For 2700K Substitute XX with 27

MEDIUM

TECHNICAL DESCRIPTION

Stacko Straight Fixed End is a Constant Current miniature display lighting product. It has four beam distributions and is a part of the modular Stacko Collection allowing users to 'stack' products together to create unique lighting set-ups that comes as standard in white, black and brushed aluminium. There are 5 light engines totalling 510lm | 5.60W. Each medium beam in our 102lm light engine has a peak intensity of 359cd. This 'End' module closes the circuit and does not accept further modules. There can only be a maximum of 10 light engines per Stacko circuit or driver. The luminaire is compatible with our Minipoint system that enables a plug and play setup where luminaires can be swapped to suit changing lighting requirements.



MECHANICAL & ELECTRICAL

CATEGORY IP20	WATTAGE 5.60W
MATERIAL Machined AL 6063-T6 Machined Brass	FORWARD VOLTAGE 16V
PAN 360°	DRIVE CURRENT 350mA
TILT N/A	SUPPLY TYPE Constant Current
LOCKABLE N/A	DRIVER LOCATION Remote
WEIGHT 79g 0.17lb	DIMMING DALI 0-10V 1-10V

MOUNTING

MOUNTING Minipoints	CUTOUT ø18mm (0.71") minipoint
CEILING THICKNESS 30mm (1.18") max	MIN CEILING VOID N/A

FINISHES

FINISHES Brushed Aluminium | White RAL9010 | Matte Black Anodised | Rubbed Bronze* | Polished Brass* | Brushed Brass* | Polished Nickel*
*Premium & custom finishes are built & finished to order. These are subject to an extended lead time & MOQ.

OPTICAL & STANDARDS

TOTAL NOMINAL LUMENS 510lm	BEAM ANGLE 23°
TOTAL DELIVERED LUMENS 460lm	CRI 95 TYP
LIGHT ENGINE DELIVERED LUMENS 92lm	TM-30 RF: 93 RG: 99
LIGHT ENGINES 5	WARRANTY 5 Years
COLOUR TEMPERATURE 2700K 3000K	STANDARDS
ACCESSORY HOLDER N/A	
ACCESSORIES N/A	

Photometry shown is for 3000K module. Please enquire for other CCT photometry. L90 50,000 hours.

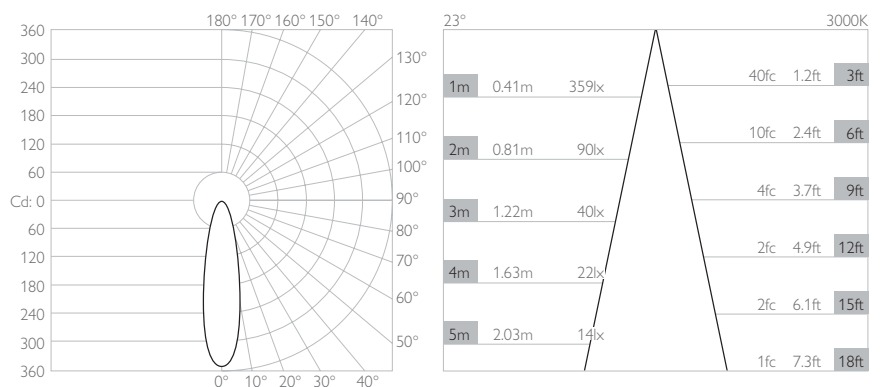
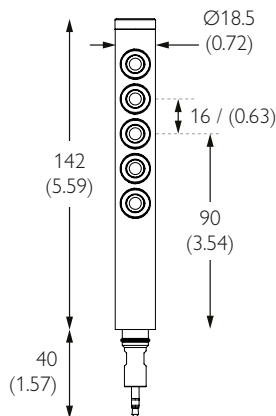
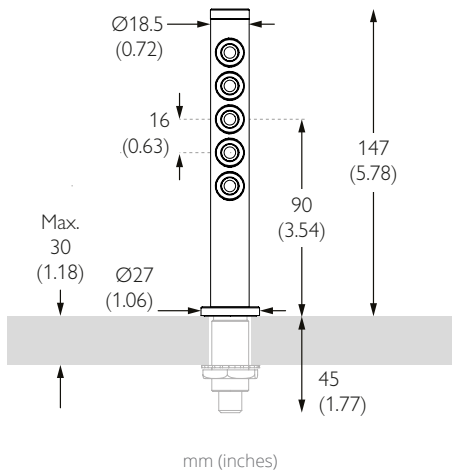

LUMINAIRE FINISH

	White 9010	Matt Anodised Black	Brushed Aluminium	Rubbed Bronze*	Polished Brass*	Brushed Brass*
Without Minipoint	1005-E-WH-XX9523	1005-E-EBA-XX9523	1005-E-AL-XX9523	1005-E-RB-XX9523	1005-E-PB-XX9523	1005-E-SB-XX9523
With Minipoint						

*All premium & custom finishes are built & finished to order. These are subject to an extended lead time & MOQ

For 3000K Substitute XX with 30

For 2700K Substitute XX with 27

FLOOD

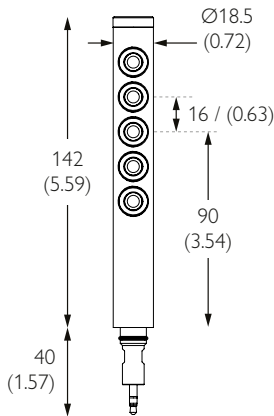
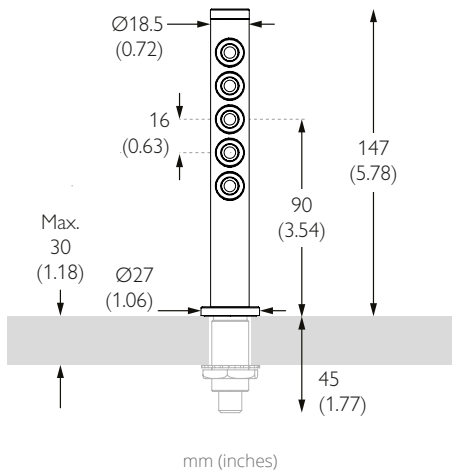

TECHNICAL DESCRIPTION

Stacko Straight Fixed End is a Constant Current miniature display lighting product. It has four beam distributions and is a part of the modular Stacko Collection allowing users to 'stack' products together to create unique lighting set-ups that comes as standard in white, black and brushed aluminium. There are 5 light engines totalling 510lm | 5.60W. Each flood beam in our 102lm light engine has a peak intensity of 109cd. This 'End' module closes the circuit and does not accept further modules. There can only be a maximum of 10 light engines per Stacko circuit or driver. The luminaire is compatible with our Minipoint system that enables a plug and play setup where luminaires can be swapped to suit changing lighting requirements.

MECHANICAL & ELECTRICAL

CATEGORY IP20	WATTAGE 5.60W
MATERIAL Machined AL 6063-T6 Machined Brass	FORWARD VOLTAGE 16V
PAN 360°	DRIVE CURRENT 350mA
TILT N/A	SUPPLY TYPE Constant Current
LOCKABLE N/A	DRIVER LOCATION Remote
WEIGHT 79g 0.17lb	DIMMING DALI 0-10V 1-10V

MOUNTING

MOUNTING Minipoints	CUTOUT ø18mm (0.71") minipoint
CEILING THICKNESS 30mm (1.18") max	MIN CEILING VOID N/A

FINISHES

FINISHES Brushed Aluminium | White RAL9010 | Matte Black Anodised | Rubbed Bronze* | Polished Brass* | Brushed Brass* | Polished Nickel*
*Premium & custom finishes are built & finished to order. These are subject to an extended lead time & MOQ.

OPTICAL & STANDARDS

TOTAL NOMINAL LUMENS 510lm	BEAM ANGLE 45°
TOTAL DELIVERED LUMENS 465lm	CRI 95 TYP
LIGHT ENGINE DELIVERED LUMENS 93lm	TM-30 RF: 93 RG: 99
LIGHT ENGINES 5	WARRANTY 5 Years
COLOUR TEMPERATURE 2700K 3000K	STANDARDS
ACCESSORY HOLDER N/A	
ACCESSORIES N/A	

Photometry shown is for 3000K module. Please enquire for other CCT photometry. L90 50,000 hours.

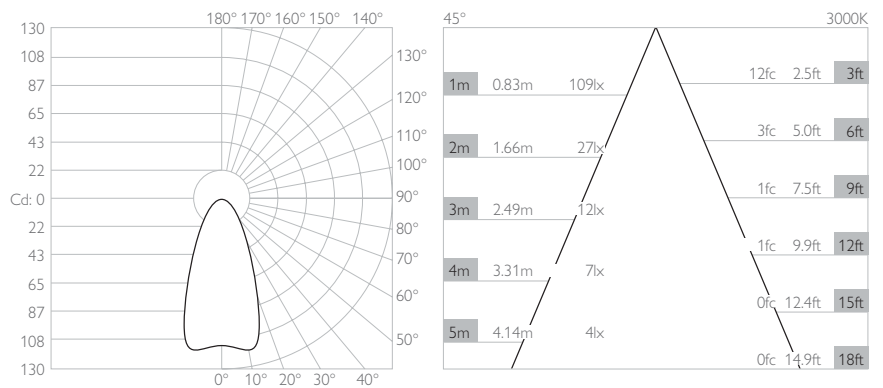

LUMINAIRE FINISH

	White 9010	Matt Anodised Black	Brushed Aluminium	Rubbed Bronze*	Polished Brass*	Brushed Brass*
Without Minipoint	1005-E-WH-XX9545	1005-E-EBA-XX9545	1005-E-AL-XX9545	1005-E-RB-XX9545	1005-E-PB-XX9545	1005-E-SB-XX9545
With Minipoint						

*All premium & custom finishes are built & finished to order. These are subject to an extended lead time & MOQ

For 3000K Substitute XX with 30

For 2700K Substitute XX with 27

WIDE FLOOD

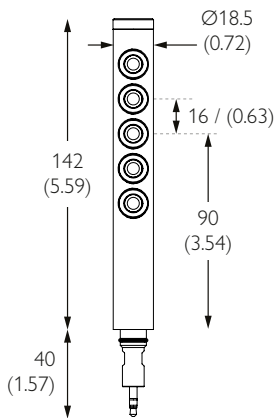
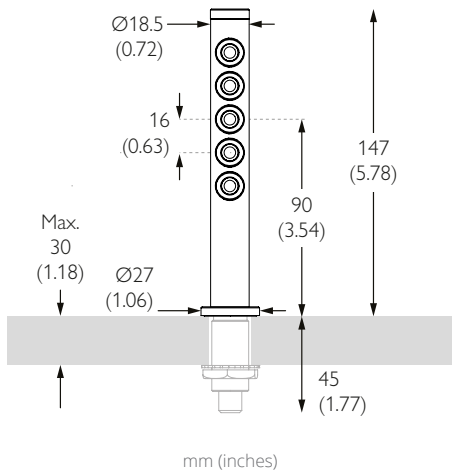

TECHNICAL DESCRIPTION

Stacko Straight Fixed End is a Constant Current miniature display lighting product. It has four beam distributions and is a part of the modular Stacko Collection allowing users to 'stack' products together to create unique lighting set-ups that comes as standard in white, black and brushed aluminium. There are 5 light engines totalling 510lm | 5.60W. Each wide flood beam in our 102lm light engine has a peak intensity of 26cd. This 'End' module closes the circuit and does not accept further modules. There can only be a maximum of 10 light engines per Stacko circuit or driver. The luminaire is compatible with our Minipoint system that enables a plug and play setup where luminaires can be swapped to suit changing lighting requirements.

MECHANICAL & ELECTRICAL

CATEGORY IP20	WATTAGE 5.60W
MATERIAL Machined AL 6063-T6 Machined Brass	FORWARD VOLTAGE 16V
PAN 360°	DRIVE CURRENT 350mA
TILT N/A	SUPPLY TYPE Constant Current
LOCKABLE N/A	DRIVER LOCATION Remote
WEIGHT 79g 0.17lb	DIMMING DALI 0-10V 1-10V

MOUNTING

MOUNTING Minipoints	CUTOUT ø18mm (0.71") minipoint
CEILING THICKNESS 30mm (1.18") max	MIN CEILING VOID N/A

FINISHES

FINISHES Brushed Aluminium | White RAL9010 | Matte Black Anodised | Rubbed Bronze* | Polished Brass* | Brushed Brass* | Polished Nickel*
*Premium & custom finishes are built & finished to order. These are subject to an extended lead time & MOQ.

OPTICAL & STANDARDS

TOTAL NOMINAL LUMENS 510lm	BEAM ANGLE 90°
TOTAL DELIVERED LUMENS 345lm	CRI 95 TYP
LIGHT ENGINE DELIVERED LUMENS 69lm	TM-30 RF: 93 RG: 99
LIGHT ENGINES 5	WARRANTY 5 Years
COLOUR TEMPERATURE 2700K 3000K	STANDARDS
ACCESSORY HOLDER N/A	
ACCESSORIES N/A	

Photometry shown is for 3000K module. Please enquire for other CCT photometry. L90 50,000 hours.

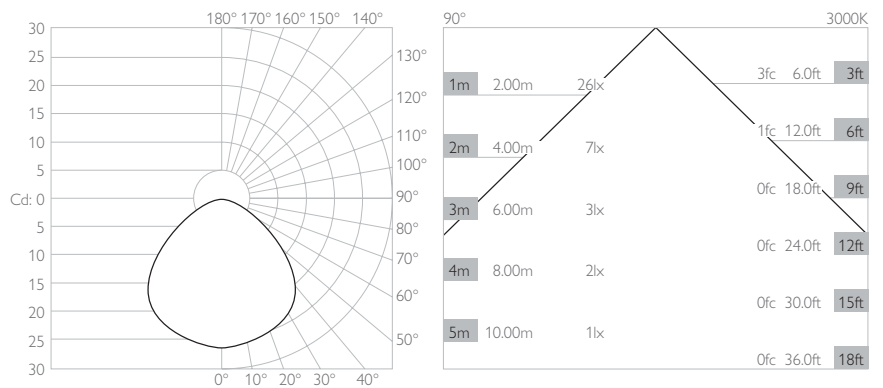

LUMINAIRE FINISH

	White 9010	Matt Anodised Black	Brushed Aluminium	Rubbed Bronze*	Polished Brass*	Brushed Brass*
Without Minipoint	1005-E-WH-XX9590	1005-E-EBA-XX9590	1005-E-AL-XX9590	1005-E-RB-XX9590	1005-E-PB-XX9590	1005-E-SB-XX9590
With Minipoint						

*All premium & custom finishes are built & finished to order. These are subject to an extended lead time & MOQ

For 3000K Substitute XX with 30

For 2700K Substitute XX with 27